

# INSTRUCTION MANUAL

## BMT-4080AH

### Precision Auto Hydraulic Surface Grinder (415V) 860 x 450mm Table Travel



G250



Established 1930

Distributors of new & used workshop Equipment

G242 BMT-1545AH

G243 BMT-2045AH

G244 BMT 2550AH with AD5 controller

G248 BMT-3060AH with AD5 controller

G250 BMT-4080AH with AD5 controller

Surface grinders

INSTRUCTION & PARTS MANUAL

31-1-12

# **HIGH PRECISION** **SURFACE GRINDERS**

## **INSTRUCTION MANUAL**

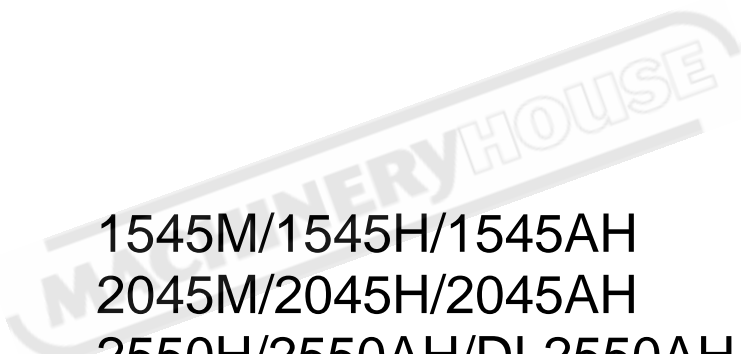

1545M/1545H/1545AH  
2045M/2045H/2045AH  
2550H/2550AH/DL2550AH  
C3060AH/DL3060AH  
D4080AH/DL4080AH

---

---

---

## TABLE OF CONTENTS

Preface .....	1
Dimension Drawing.....	2
Warning indicator specification .....	3
<b>Part A. Installation Instruction</b>	
1. Selection of Location .....	A-1
2. Diagram of Machine Space .....	A-1
3. Foundation and foundation bolts.....	A-2
4. Carriage .....	A-2
5. Lay down the machine .....	A-3
6. Mountin the table.....	A-3
7. Remove the Setting Plates.....	A-4
8. Clean the Machine.....	A-4
9. Leveling .....	A-5
10.Placement of Hydraulic System .....	A-5
11.Installation of Coolant System .....	A-6
12.Connection of Power Line .....	A-6
<b>Part B. Operation Instruction</b>	
1. General Safety Regulation.....	B-1
2. Construction Identification .....	B-2
3. Capacity of Machine .....	B-3
4. Allowable Machining Load of Machine .....	B-4
5. Traveling Direction .....	B-4
6. Panel Location Diagram and Function .....	B-5
7. Grinding Wheel Selection and Mounting.....	B-8
8. Cross Movement of Saddle.....	B-13
9. Longitudinal Movement of Table .....	B-14
10.Vertical Movement of Wheel Head.....	B-19
11.Automatic Demagnetization.....	B-19
12.Chuck before Grinding Operation.....	B-20
13.Operation Testing .....	B-20
14.General Operation Mode.....	B-20
15.Maintenance.....	B-22
16.Trouble Shooting .....	B-26
17.Use of the optional attachment.....	B-30
<b>Part C. Electric Diagram and Parts List</b>	
1. The Difference Table of All Machine Model.....	C-1
2. Installation Instruction and Drawing.....	C-5
3. Circuit Diagram .....	C-9
4. Material Partlist.....	C-24
<b>Part D. Complete Drawing and Parts List</b>	
Contents .....	D-1

## **PREFACE**

This instruction manual is used for the safe operation and maintenance of the Precision Surface Grinding Machine made by **PERFECT** Machine Co., LTD.. This instructions manual should be kept close to the machine or the place the operators can easily access to it. The operators should be well trained so that safe operation and maintenance can be assured.

This machine is designed completely abide by the rules regulated in the EC Machinery Directive (98/371/EEC) and other recommendations mentioned in the relative EN harmonic standards. Therefore, it is very important to be carefully in using of the machine for the purpose of ensuring security. Proper management and training based on the instruction for safety operation is important and should be completely followed for avoidance of operators being injured. In case of accident, the reasons should be analyzed to prevent similar accidents from happening again in the future.

Do not modify electrical circuits, machine, electrical components and machine parts without being authorized by our company. Our company shall bear no liability for any hazard, properties loss, and personnel injury in case of arbitrary modification.

All the figures and diagrams in this instructions manual provided most up to date information related to the type of machine the client bought. On receiving the machine, customers are required to make sure the model number on the cover of instructions manual is same as the machine one bought. In the condition of proper usage and maintenance, **PERFECT** Machine Co., LTD. warrants one-year after-service for new machines failure under the normal working condition. If the damage of the machine is due to improper operation or maintenance or other natural or man made disaster, then this warranty should be excluded.

Please check all the parts and accessories according to the packing list when you receive the machine. Do not hesitate to contact our local dealers or headquarters of **PERFECT** Machine Co., LTD. in Taiwan. If there is any complaint or service requirement, please directly contact our local distributors.

## DIMENSION DRAWING

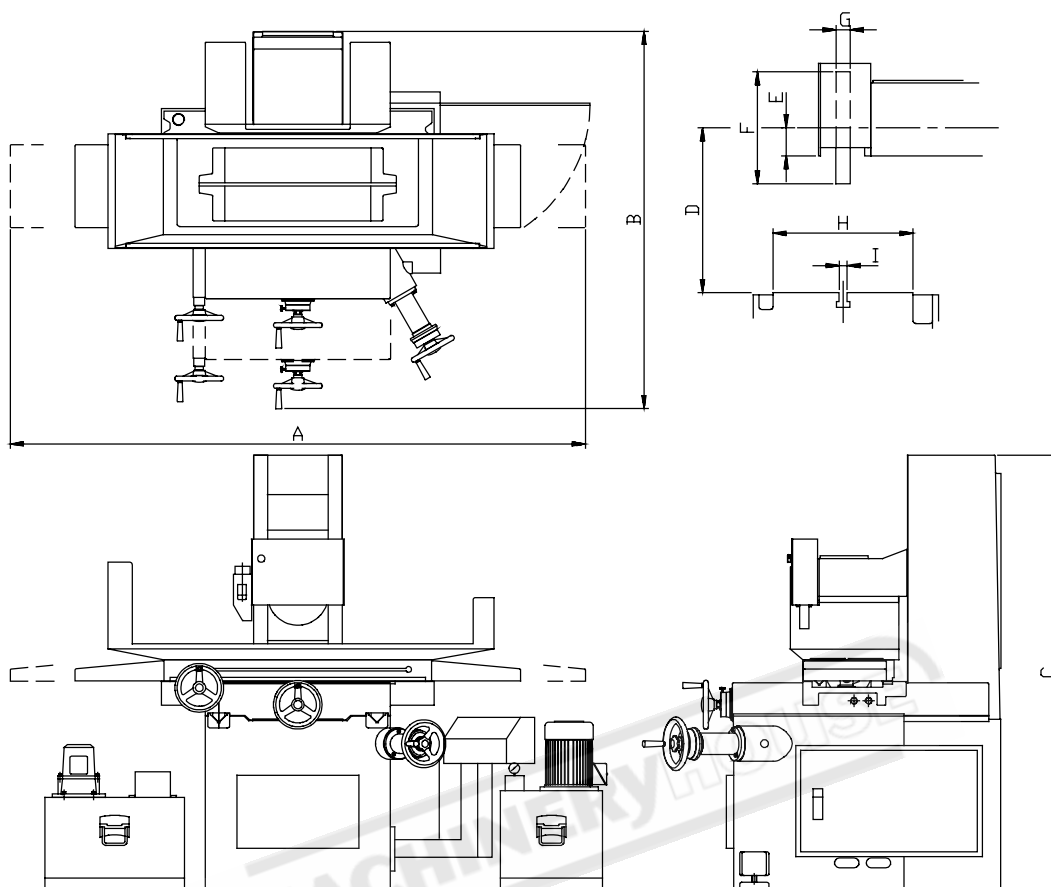



MODEL	1545M 2045M	1545H/AH 2045H/AH	2550	C3060	D4080
A	1900mm	2100mm	2250mm	2650mm	3000mm
B	1200mm 1300mm	1200mm 1300mm	1400mm	1550mm	2000mm
C	1700mm	1700mm	1800mm	2100mm	2150mm
D	460mm	460mm	500mm	500mm	550mm
E	50mm	50mm	50mm	80mm	95mm
F	180mm	180mm	180mm	355mm	406mm
G	13mm	13mm	13mm	38mm	50.8mm
H	150mm 200mm	150mm 200mm	250mm	300mm	400mm
I	15mm	15mm	15mm	15mm	15mm

# WARNING INDICATOR SPECIFICATION

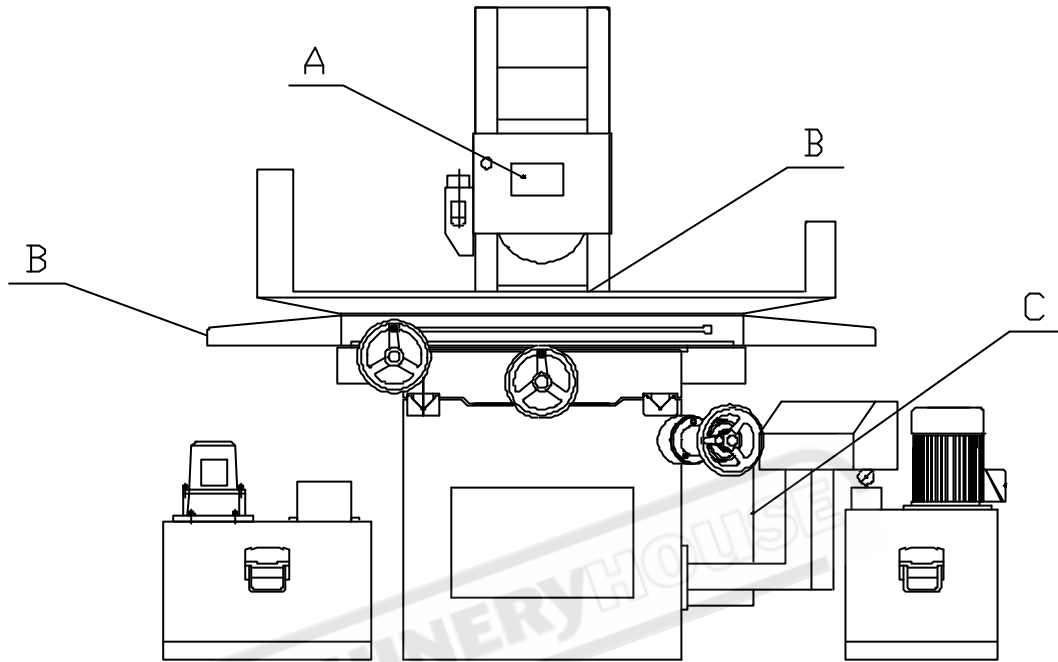
\* The position figure of the warning indicators.

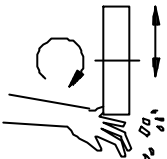

A. GRINDING WHEEL WARNING INDICATOR

 <span style="font-size: 2em; font-weight: bold; margin-left: 10px;">WARNING</span>

<p>1. WHEN CHANGING THE GRINDING WHEEL MUST BE TURN OFF THE SPINDLE.</p> <p>2. MUST BALANCE THE WHEEL BEFORE MOUNTING IT ONTO THE SPINDLE.</p>

<p>NEVER PUT HANDS NEAR GRINDING WHEEL OR REMOVE WORKPIECES FROM TABLE BEFORE WHEEL ROTATION COMPLETE STOP.</p>

Obey the indicator to avoid danger when you operate the machine.



Shows the spindle rotatory spindle direction.

B. OPERATION WARNING INDICATOR

<span style="font-size: 2em; font-weight: bold;">WARNING!</span>	<p>Be care of hands for cutting while machine is moving.</p>
--	--



## C. RATED VOLTAGE AND CURRENT INDICATOR

CURRENT CHART	
380V/3ph/50Hz	
RATE CURRENT	19 A
MAX. CURRENT OF SPINDLE MOTOR	8.3 A
CURRENT CHARGE OF INTERRUPT	25 A
ATTENTION ! TO BE GROUNDED ACCORDING TO LOCAL REGULATIONS!	

\* The current charge is different according to the premiered voltage of the machine specifications.

## A. INSTALLATION INSTRUCTION

### 1. SELECTION OF LOCATION

To upgrade the operation efficiency and accuracy of precision machine, a proper foundation is required.

Precision grinding machine shall not be adjacent to machines such as planing machine, milling machine, molding or puching machine. Otherwise, it will result in poor grinding accuracy.

### 2. DIAGRAM OF MACHINE SPACE :

unit:mm

MODEL	A	B	C
1545M 2045M	2600	2100	1700
1545H/AH 2045H/AH	3080	2200	1700
2550H/AH	3250	2400	2000
C/D3060AH	3650	2550	2100
D4080AH	4000	3000	2150

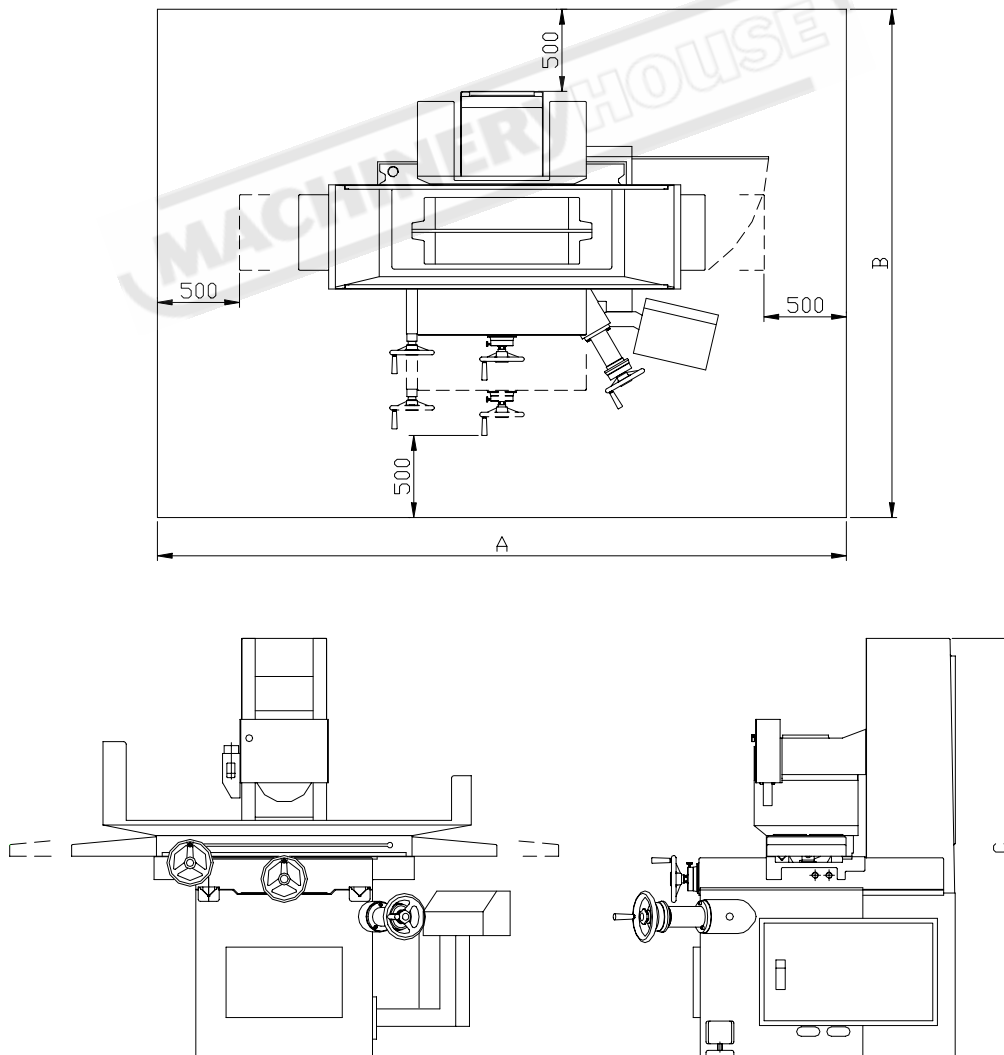

### 3. FOUNDATION AND FOUNDATION BOLTS

unit: mm

MODEL	A	B	C	D
1545/2045	652	550	-	-
2550	852	600	-	-
C/D3060	397	585	590	700
D4080	475	830	845	955

C1545~2550

C3060~D4080

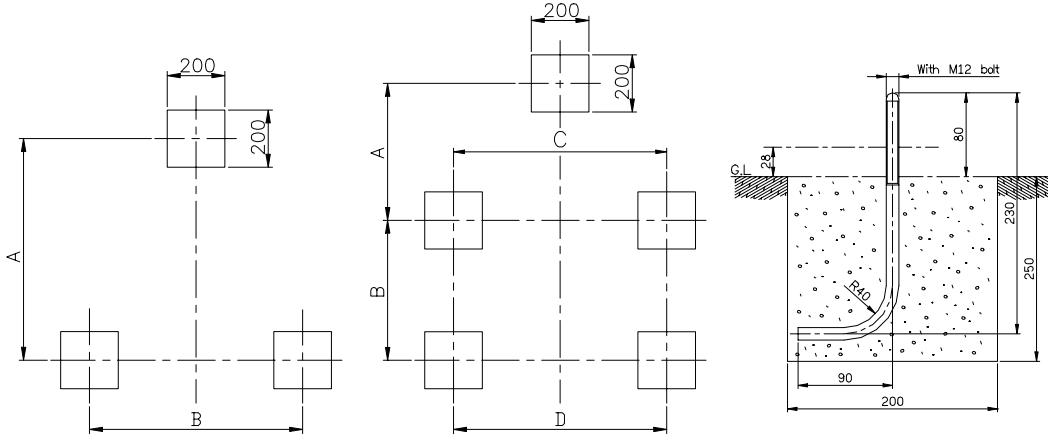

### 4. CARRIAGE

Use following equipment to lift the machine.

- (1) Lifting: First fasten the sling bolts on the machine base, then set the wire cables on the sling bolts and the hook.

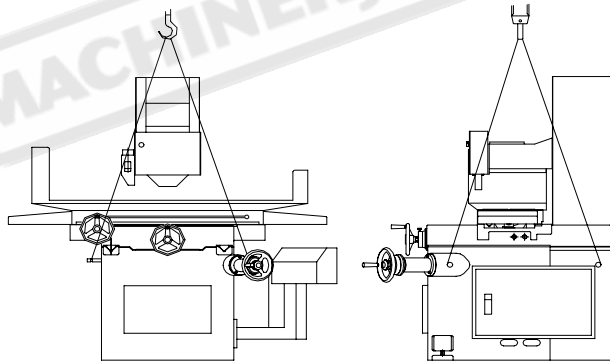

- (1) Crane: 4 tons capacity
- (2) Wire cable:  $\varnothing 16\text{mm} \times 2000\text{mm} \times 4$
- (3) Sling bolt: 4pcs

- (2) Carriage by fork lift and rolling bar

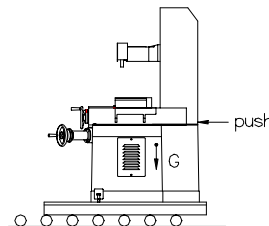
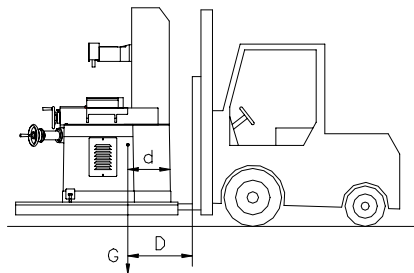

G: center of gravity  
d: about 450mm  
D: as small as

(3) MACHINE WEIGHT

MODEL	WEIGHT(kgs)	MODEL	WEIGHT(kgs)
1545M	870	2550H/AH	1350
1545H/AH	900	C3060AH	1700
2045M	920	D4080AH	3250
2045H/AH	950		

5. LAY DOWN THE MACHINE

Before laying down the machine, fix the adjusting screws on the base, make the machine as close as possible to the floor, and position the leveling pads in place, so as to increase the stability of machine.

In the event of transporting a machine by fork lift or rollers, remove the set screws which secure machine on wooden base before laying down the machine.

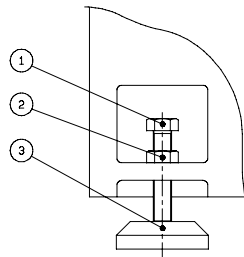

- ① Leveling screw
- ② Nut
- ③ Leveling pad

6. MOUNTIN THE TABLE

The machine is despatched completed with the exception of table, so as to protect the harden and ground slideways from damage during shipment. When the machine installed, mounting the table as following procedures.

MANUAL TYPE :

- (1) Wind the wire rope on the "Drum" 4 turns as figure shown, tightening the wire and fix it temporarily.

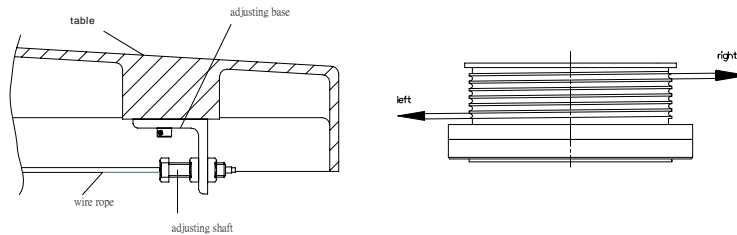

- (2) Put the steel ball retainers right in the middle of slide ways.
- (3) Lift up the table and place it on the steel ball retainers. To prevent slide ways from damaging, please handle wire care.
- (4) Fix the wire rope on the fixed stand.
- (5) The wire will loose after long use, and will cause table move unsmoothly. In this case please adjust the adjusting bolt at the right and till it it's in tightening condition.

- (6) The quantity of steel ball:

MODEL	1545M	2045M
Flat way	23	23
V-way	21	21
TOTAL	44	44

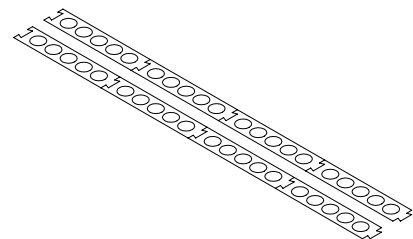

## 7. REMOVE THE SETTING PLATES

When the machine is positioned and no need to change location again, remove the anchor plates.(refer to pictures)

- Note:(1) Properly preserve the removed anchor plates which may be used again when the machine requires carriage in the future. However, if the plates are lost, it is recommended to contact locate distributor or our company for purchase or manufacturing in your country.
- (2) Do not force the front/rear or left/right hand-wheelsto revolve before anchor plates are removed.

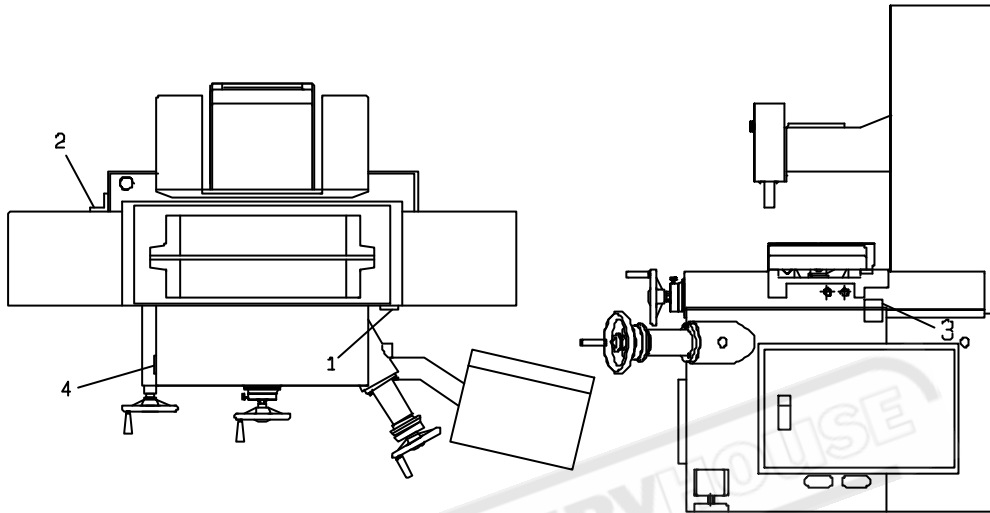

## 8. CLEAN THE MACHINE

All the machine are provided with anti-rust treatment. Themoving parts are lubricated with grease and fixture points and dye black portions are applied with anti-rust oil.

### 8-1 For M type

So for better operation and lubrication effect, please clean up the following three points before moving the three axis travel:

- (1) elevation slide way.
- (2) steel ball rolling way.
- (3) saddle V groove.

### 8-2 For H/AH type

Use a soft cloth with kerosene to clean the parts surface covered by anti-rust oil. If the grease on the parts is fouled, use soft cloth to clean these parts and apply new clean grease again.

### 9. LEVELING

- (1) Use following tools to adjust machine leveling:
  - a. Two precision spirit levels(spec.: 0.02mm/1000mm)
  - b. Two open-end wrenches(M20)
- (2) Firstly clean the table. Set one spirit level at the longitudinal direction and the other at cross of the table.

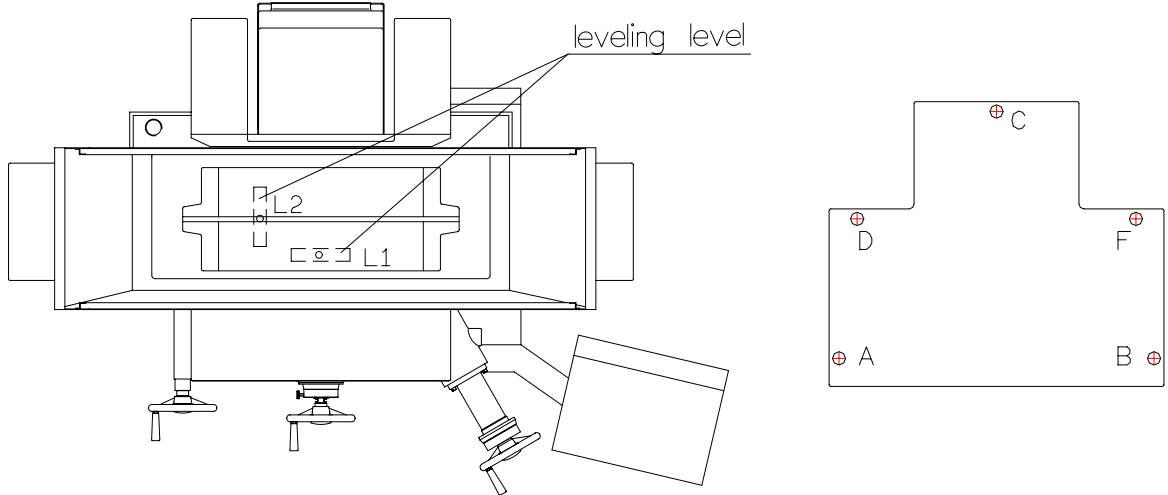

- (3) Firstly adjust two adjusting bolts(A and B) till leveling L1 is indicated by the spirit levelers then adjust the adjusting bolts(C).
- (4) Tighten setting nut.  
 Remark: There are five adjusting bolts for C/D3060 and D4080. To adjust leveling loosen D; F bolts, and following upper adjusting produce, when finished. Turn and adjust the adjusting bolts D and F to hold on leveling pad.
- (5) For a new machine, it is necessary for weekly leveling. When the foundation is proved to be steady, perform leveling every six months instead.

### 10. PLACEMENT OF HYDRAULIC SYSTEM(H,AH)

- (1) Connect the circuit of hydraulic motor to the electric box.  
 Note: About weight of the hydraulic tank, all serial with full oil refer to the following. Be careful of lifting.

Units: kg

MODEL	WEIGHT
1545~2550	180
C3060	180
D4080	230

- (2) Connect the two oil pressure pipe to the tanks in the front and rear in place.
- (3) Suggested Capacity of the hydraulic oil tank as follows. Examine the oil level come to the middle point of the meter.

Units: Liters

MODEL	CAPACITY
1545~2550	60
C3060	60
D4080	120

- (4) Quantity and standards of hydraulic oil: SHELL-TELLUS32; ESSO-NUTO H32; MOBIL-VALCUOLINE 1405; MOBIL-D.T.E Light 4
- (5) The pressure of hydraulic system has been adjusted (about 12-16kg/cm<sup>2</sup>) in our factory before delivery. Do not adjust it in normal condition.
- (6) The oil should be change by new oil after one months of operation at first time. **The General lubricants for machine tools**

	SYMBOL	CPC	ESSO/EXXON	SHELL	MOBIL	DAPHNF
Gears	CB 32	R 32	Teresso 32	Tellus Oil C 32	DTE Oil Light	Mechanic Oil 32
	CB 68	R 68	Teresso 68	Tellus Oil C 68	DTE Oil Heavy Medium	Mechanic Oil 68
	CB 150	R 150	Teresso 150	Tellus Oil C 150	DTE Oil Extra Heavy	Mechanic Oil 150
Gears	CC 150	R 150	Spartan EP 150	Omala Oil 150	Gear 629	CE Compound 150S
	CC 320	R 320	Spartan EP 320	Omala Oil 320	Gear 632	CE Compound 320S
	CC 460	R 460	Spartan EP 460	Omala Oil 460	Gear 634	CE Compound 460S
Bearings	FC 2	R 12	Spinesso 10	High spin oil C2	Velocite Oil No. 3	Mechanic Oil 2
	FC 10	R 22	Spinesso 22	Tellus Oil C 10	Velocite Oil No. 6	Mechanic Oil 10
	FC 22			Tellus Oil C 22	Velocite Oil No. 10	Mechanic Oil 22
Slide Ways	G 68	Slide way oil	Febis K 68	Tonna T 68	Vactra Oil No. 2	Multiway 68C
	G 220	Slide way oil	Febis K 220	Tonna T 220	Vactra Oil No. 4	Multiway 220C
Hydraulic System	HL 32	R 32	Teresso 32	Tellus Oil C 32	DTE Oil Light	Hydraulic Fluid 32
	HL 68	R 68	Teresso 68	Tellus Oil C 68	DTE Oil Heavy Medium	Hydraulic Fluid 68
	HM 32	32 AW	Nuto HP 32	Tellus Oil 32	DTE 24	Super Hydraulic Fluid 32
	HM 68	68 AW	Nuto HP 68	Tellus Oil 68	DTE 26	Super Hydraulic Fluid 68
	HG 32		Powerex DP 32	Tonna Oil T 32	Vacuoline Oil 1405	Multiway 32
	HG 68		Powerex DP 68	Tonna Oil T 68	Vacuoline Oil 1408	Multiway 68

### 11. INSTALLATION OF COOLANT SYSTEM

- (1) coolant system is usually located at the left side of the machine please connect the hose of coolant pump to the steel pipe which fixed at the right handside of column. After the power cable of coolant pump motor is plugged to the plug in electric box or machine bas.
- (2) When use the coolant system , it must add coolant into the tank,the coolant must be anti-rust; protect hand and protect paint of machine.
- (3) Please do not supply the coolant to grinding wheel and spindle when the wheel stopping or starting. Because supply coolant that may easily caused Bearing to damage or grinding wheel to be unbalanced.
- (4) Suggested Capacity of the coolant tank as follows

unit: Liter

MODEL	1545~ C3060	D4080
AMOUNT CAPACITY	52	95
RECOMMENDED CAPACITY	42	76
COOLANT PUMP SPEC.	1/8HP×2P	

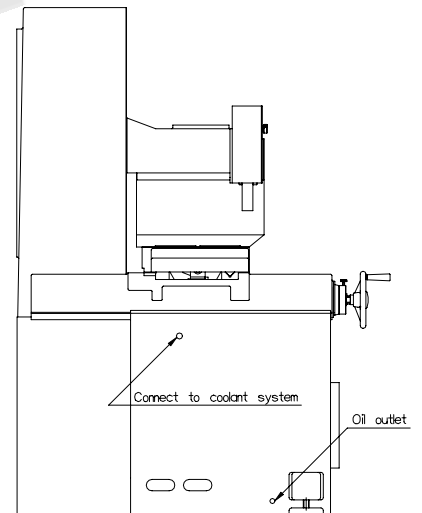

### 12. CONNECTION OF POWER LINE

- (1) Make sure the power voltage is same as machine voltage.
- (2) The main power line can be connected into the electric box to be tightened to the terminal through the button of the box.
- (3) Use 4 cords and the cross sectional area is at least 4.0mm<sup>2</sup> for the power line, connected to ground and over voltage protector according to the local electricity regulations. For wiring to different voltage, be sure to rewire hydraulic pump motor, spindle motor and transformer to the correct voltages. And to replace fuses to protect the electrical components. Using the current chart as refer to part C, or contact our agents for detail.

Note: Do not use machine if its voltage preset is different from external power supply. Contact electric technician for reparation if necessary.

## B. OPERATION INSTRUCTIONS

### 1. GENERAL SAFETY REGULATIONS

- (1) This machine is only used for metal grinding. No flammable materials such as wood or plastic shall be used.
- (2) The owners shall carefully select qualified operators with proper grinding training to operate and maintain the machine.
- (3) The owners shall demand operators to participate in safety seminars and practices.
- (4) Read this instructions manual carefully before operating machine.**
- (5) All the guards and doors shall be closed at all times except that maintenance is required.
- (6) Do not attempt to clear the chips from workpiece before finishing of grinding.
- (7) Check grinding wheel and make sure the spindle turns at clockwise direction before actuating spindle motor. Let grinding wheel to run idly for at least five minutes.
- (8) Wear goggles, mouthpiece (especially during dry grinding), and safety shoes when operating machine.
- (9) Do not wear loose clothes, long sleeves and neckties during operation.
- (10) Wear protective hair covering or hold hat to prevent long hair from falling down during operation.
- (11) Keep the area around machine clean and dry. Remove clogs and scrap.
- (12) Use electromagnetic chuck to hold workpiece. Clean the surface of the chuck before holding. Regrind the chuck surface if any scratch on it.
- (13) Be careful of sharp angles and high temperature while loading and unloading workpiece. Use a crane to help loading/unloading large workpiece with weight over 25kg.
- (14) During grinding, clear all unnecessary objects other than workpiece from the machine.
- (15) After switching off the spindle motor, allow the spindle to stop freely. Never attempt to stop the grinding wheel by hand or other objects.
- (16) During wet grinding, do not try to adjust nozzle after spindle starts. Stop coolant before switching off spindle motor.
- (17) Never open electric box without being approved. Consult the electrical technician or qualified electrical engineers for electric trouble shooting.
- (18) This machine can not be used in the explosive environment.**
- (19) Other safety regulations should follow the local laws.



## 2. CONSTRUCTION IDENTIFICATION

NO.	Name of Parts	NO.	Name of Parts
1	Column	10	Table stroke adjusting unit
2	Parallel wheel dresser (Option)	11	Saddle crossfeed handwheel
3	Wheel cover	12	Control panel
4	Suction device	13	Control panel support
5	Splash guard	14	Wheelhead elevating handwheel
6	Table	15	Electric box
7	Table movement handwheel	16	Hydraulic tank
8	Saddle	17	Base
9	Coolant system (Option)		

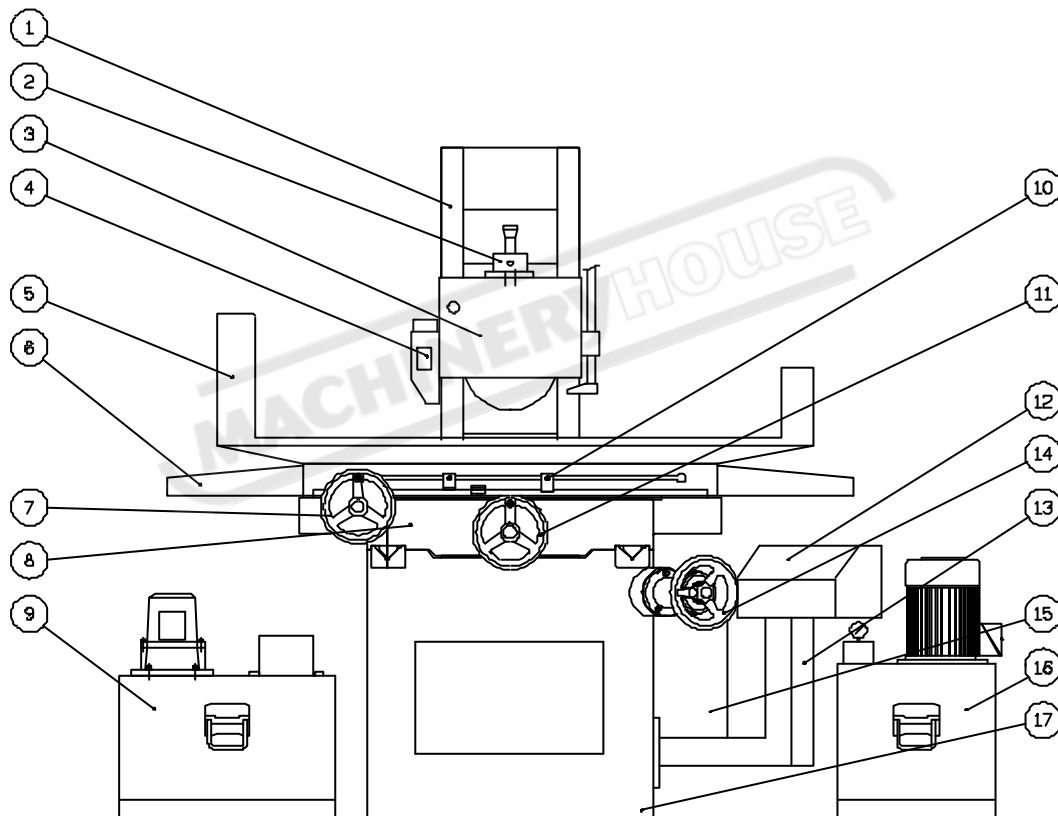

### 3. CAPACITY OF MACHINE

Specifications	1545M	1545H 1545AH	2045M	2045H 2045AH
Table size	150×450mm		200×450mm	
Max. surface ground	150×450mm		200×450mm	
Max. distance center of spindle to table	450mm			
Table speed	Manual	5-25M/mim	Manual	5-25M/mim
Table guideway	Ball rolling way	V & Flat way	Ball rolling way	V & Flat way
Auto cross feed increment	Manual	Manual (for H) 0.1mm-12mm	Manual	Manual (for H) 0.1mm-12mm
Rapid power cross feed [50Hz] [60Hz]	Manual	Manual (for H) 900mm/min 1100mm/min	Manual	Manual (for H) 900mm/min 1100mm/min
Cross feed on hand Wheel 1 rev/1gra	5mm/0.02mm			
Rapid power wheel head (Optional) [50Hz] [60Hz]	450mm/min 550mm/min			
Vertical down feed on wheel head 1 rev 1 gra	2mm 0.01mm(stand)/0.005mm(with AD5)			
Auto. down feed (Optional)	0.001mm~0.999mm			
Wheel speed [50Hz] [60Hz]	3500R.P.M 2900R.P.M.			
Wheel dimension mm	180×13×31.75 (max. 200×20×31.75)			
Spindle motor	2HP			
Hydraulic drive	None	1HP	None	1HP
Auto cross feed motor	None	25W	None	25W
Rapid head elevation motor (Optional)	<sup>1</sup> / <sub>5</sub> HP			
Coolant pump (Option)	<sup>1</sup> / <sub>8</sub> HP			
Machine net weight kgs	870	900	920	950
Machine gross weight kgs	970	1100	1020	1150
Machine floor space mm	1600×1100	2080×1200	1600×1100	2080×1200
Packing dimension cm	182×128×195	212×146×195	182×128×195	212×146×195

Specifications	2550H 2550AH	CL3060AH	DL3060AH	D4080AH
Table size	250×500mm	300×600mm		400×800mm
Max. surface ground	250×500mm	300×600mm		400×800mm
Max. distance center of spindle to table	500mm	500mm		550mm
Table speed	5-25M/mim			
Table guideway	V & Flat way			
Auto cross feed increment	Manual (for H) 0.1mm-12mm	0.5mm~20mm		
Rapid power cross feed approx	Manual (for H) 900mm/min(50Hz) 1100mm/min(60Hz)	900mm/min(50Hz) 1100mm/min(60Hz)		
Cross feed on hand Wheel 1 rev 1 gra	5mm 0.02mm			
Rapid power wheel head (Optional) [50Hz] [60Hz]	450mm/min 550mm/min			
Vertical down feed on wheel head 1 rev 1 gra	2mm 0.01mm	2mm 0.01mm	2mm 0.005mm	2mm 0.01mm
Auto. down feed (Optional)	0.001mm~0.999mm/Time			
Wheel speed [50Hz] [60Hz]	2900R.P.M. 3500R.P.M.	1450R.P.M. 1750R.P.M.		
Wheel dimension mm	180×13×31.75 (max.200×20×31.75)	355×38×127		406×50×127
Spindle motor	2HP	5HP		5HP
Hydraulic drive	1HP			2HP
Auto cross feed motor	<sup>1</sup> / <sub>5</sub> HP			
Rapid head elevation motor (Optional)	<sup>1</sup> / <sub>5</sub> HP			
Machine net weight kgs	1350	1700		3250
Machine gross weight kgs	1550	1950		3500
Machine floor space mm	2250×1400	2600×1800		3450×2000
Packing dimension cm	212×146×200	228×179×210		276×228×215

### 4. ALLOWABLE MACHINING LOAD OF MACHINE

The maximum allowable machining load of this machine is recommended as follows:

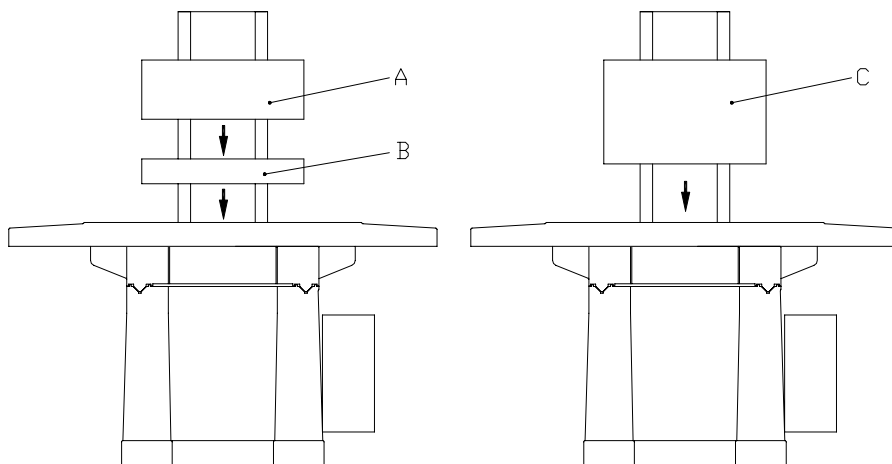

A=Workpiece  
 B=Electromagnetic chuck  
 C=A+B

Total Maximum Safety Load:

				units:kgs			
MODEL	A	B	C	MODEL	A	B	C
1545M	80	34	114	2550H/AH	190	60	250
1545H/AH	110	34	144	C/D3060AH	215	85	300
2045M	80	40	120	D4080AH	250	150	400
2045H/AH	110	40	150				

### 5. TRAVELING DIRECTION

X=Longitudinal travel of table  
 Y=Vertical travel of wheel head  
 Z=Cross travel of saddle

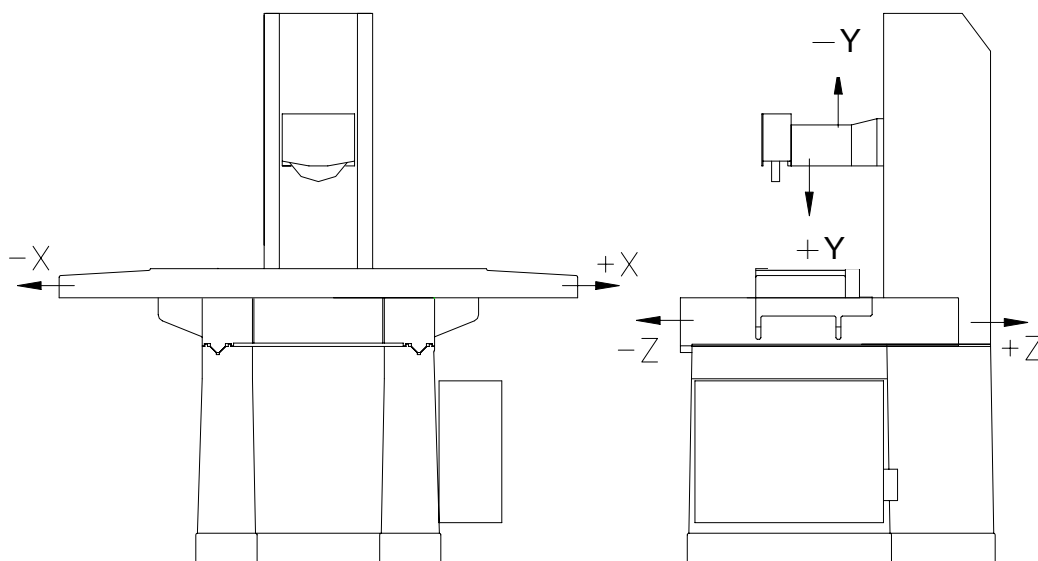

## 6. PANEL LOCATION DIAGRAM AND FUNCTION

### 6-1 PANEL LOCATION DIAGRAM

M type: three axes are manual.

H type: longitudinal by hydraulic, and cross & vertical axes are manual.

AH type: auto. cross feed & hydraulic longitudinal, and vertical axis is manual.

For "M" model

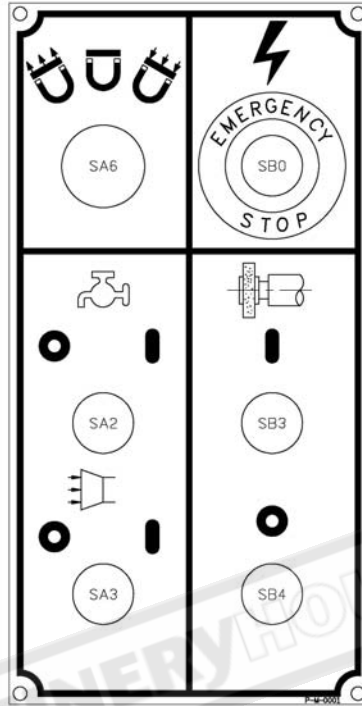

For "H" model

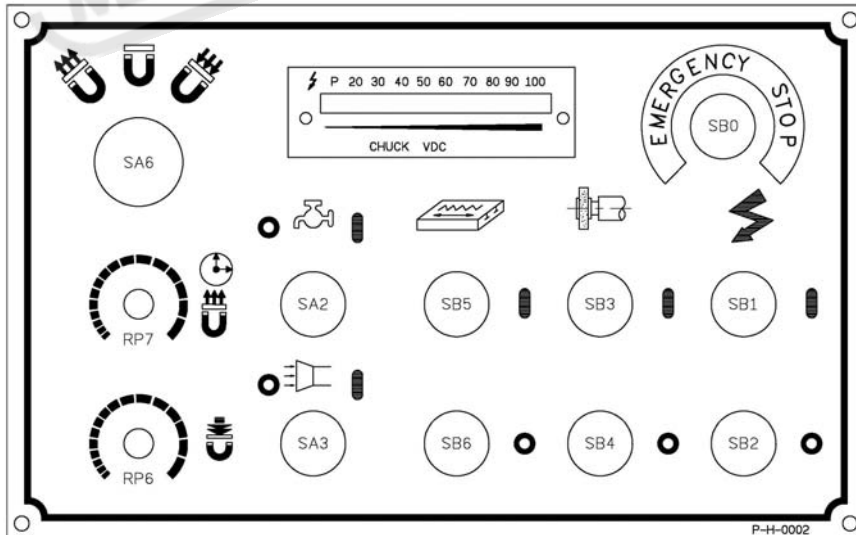

- |                                 |                                       |
|---------------------------------|---------------------------------------|
| PV1- Electromagnetic chuck LED. | SB5 - Hydraulic ON.                   |
| SB0 - Emergency stop button.    | SB6 - Hydraulic OFF.                  |
| SB1 - Power ON.                 | SA2 - Coolant system ON & OFF.        |
| SB2 - Power OFF.                | SA3 - Dust suction system ON & OFF.   |
| SB3 - Spindle ON.               | SA6 -Magnetic selection button.       |
| SB4 - Spindle OFF.              | RP6- Magnetized voltage adjustment.   |
|                                 | PR7- Demagnetization time adjustment. |

## For "AH" mode

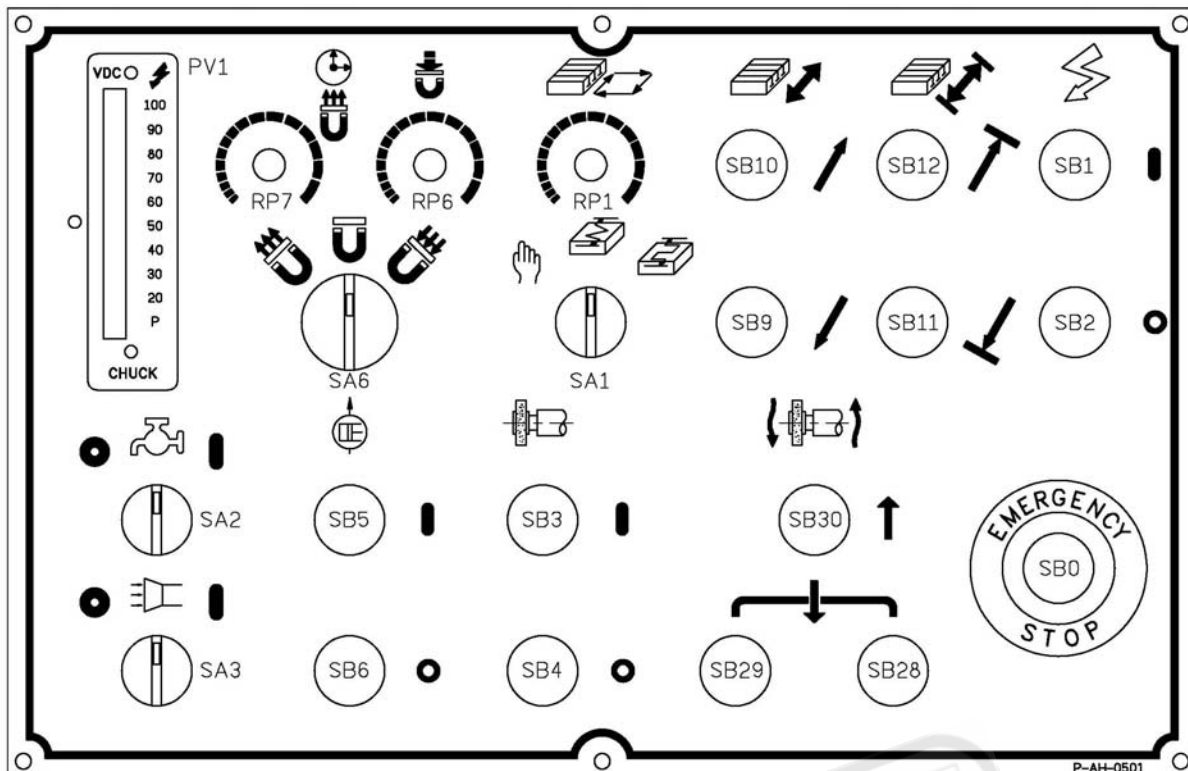

PV1 - Electromagnetic chuck LED.

SB0 - Emergency stop button.

SB1/SB2 - Power On and OFF.

SB3/SB4 - Spindle ON and OFF.

SB5/SB6 - Hydraulic ON and OFF.

SA2 - Coolant system ON and OFF.

SA3 - Dust suction system ON and OFF.

SB9/SB10 - Table moves forward and backward.

SB11/SB12 - Cross travel setting for forward and backward.

SB28/SB29 - Rapid head elevation (Down).

SB30 - Rapid head elevation (Up).

SA1 - Cross feed auto or manual selection.

SA6 - Magnetic selection button.

RP1 - Cross feed adjustment.

RP6 - Magnetized voltage adjustment.

RP7 - demagnetization time adjustment.

## 6-2 INTRODUCTOIN TO THE FUNCTIONS OF MAIN CONTROL PANEL

NO	ITEM	DESCRIPTION
PV1	Electro magnetic chuck LED	To display the electro magnetic chuck voltage.
SB0	Emergency stop button	To disconnect control power.
SB1/SB2	Power ON & OFF	To start or stop control power.
SB3/SB4	Spindle ON & OFF	To start or stop spindle motor.
SB5/SB6	Hydraulic ON and OFF	To start or stop hydraulic motor.
SB7 SB8	Coolant or dust suction system ON & OFF	To start of stop coolant pump.
SB9 SB10	Table moves forward and backward	When "SA1" turn left can start cross feed for backward.
SB11 SB12	Cross travel setting for forward and backward	When push the "SB11", it will be set cross travel to forward or push the "SB12", it will be set cross travel to backward.
SB28 SB29 SB30	Rapid head elevation (DOWN) Rapid head elevation (DOWN) Rapid head elevation (UP)	When push the "SB30", grind head will be up or push the "SB28" & "SB29" concurrently, the grind head can be down feed.
SA1	Cross feed auto or manual selection	Left- manual. Middle- automatic criss-cross grinding. Right- automatic cross feed grinding.
SA6	Magnetic selection button	Left- magnetized. Middle- lack of magnetic force. Right- demagnetized.
RP1	Cross feed adjustment	Increase at clockwise adjusting. Decrease at counter-clockwise adjusting.
RP6	Magnetized voltage adjustment	Increase at clockwise adjusting. Decrease at counter-clockwise adjusting.
PR7	Demagnetization time adjustment	Increase at clockwise adjusting. Decrease at counter-clockwise adjusting.

## 7. GRINDING WHEEL SELECTION AND MOUNTING

### 7-1 GRINDING WHEEL SELECTION

The wheel which can be used in a high speed rotation machinery, is an universal grinding tool for the grinding of varied materials. It will eject chips and dust while grinding. For the purpose of keeping operators in good health, the following items should be taken care :

- (1) The grind wheel should not be made of crystalline silicic acid.
- (2) Use the standard grinding wheel of ISO.
- (3) Make a sound test of the grinding wheel before using it.

The method of test are:

- a. Testing tools: Use wood hammer for thick wheel, and use screw driver handle for thin wheel.
- b. Tap the wheel about 45 degrees each side of the vertical center line and about 25 or 50 mm from the periphery as by the spots.

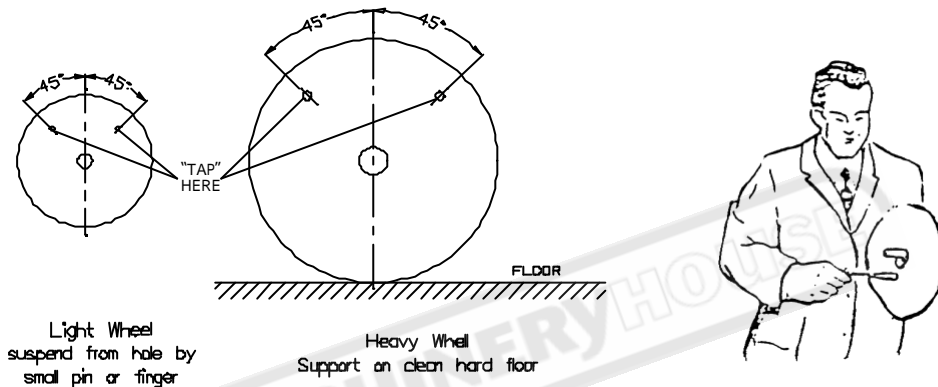

- c. Chuck whole circumference for small cracks.
- d. A good grinding wheel will give a clear sound at any tap point.
- e. Wheels must be dry and free from saw dust when applying the ring test, otherwise the sound will be deadened.

### 7-2 MOUNTING THE GRINDING WHEEL ON THE FLANGE

- (1) The flange must be kept clean absolutely when put grinding wheel on it. Tighten the clamp using nut securely, but do not over tighten it because it will cause the wheel to be cracked.
- (2) Tighten the flange can make sure the grinding wheel and the shaft to be in a security mounting situation, so the grinding wheel and the flange must be suitable for each other to avoid the stress on wheel.
- (3) There must be an elastic washer between the wheel and flange to separate the roughness of the grinding wheel from flange. The elastic washer is also used to distribute the pressure.
- (4) Do not use paper washer. Because during the wet grinding the paper will expand and will curl up while drying. It is better to use a rubber washer.

## 7-3 BALANCING

The grinding wheel must be dressed before balancing.

The balancing method is according to the operation of the bubble balancing racket. as shown:

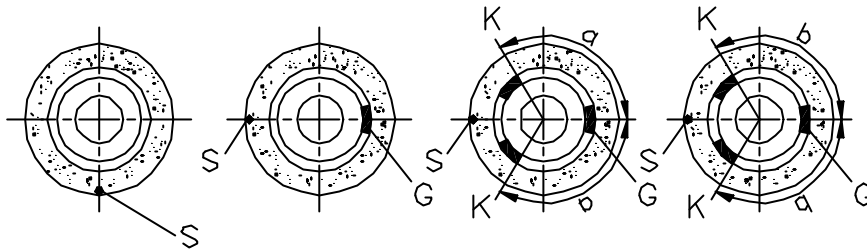

- (1) Let the wheel rolling on the stand freely to find out its gravity center "s" and mark it with chalk.
- (2) Insert a balancing weight on the opposite "G" of "S", rotate the wheel 90° to find out "S" or "G" side is heavier.
- (3) Insert two balancing weights at lighter side points "K" which are of the same circle surface as "G" point.
- (4) Rotate the wheel 90° to check the balance of the wheel. If it is still out of balance, readjust two weights "K" position until grinding wheel is really balanced. When grinding workpieces with different materials, change the wheel together with its flange to save the time required for balancing the wheel.

## 7-4 MOUNTING THE WHEEL TO SPINDLE

- (1) Double check wheel is well balanced before installation, although it has been balanced by our staff.
- (2) Clean the tapered surface of spindle and oil it.
- (3) Carefully place the wheel with flange onto the taper portion and make sure mating is firm.
- (4) Place a spindle locknut onto the thread portion of the taper.
- (5) Fasten the wheel by using the wrench attached with machine and rotate counter-clockwise.

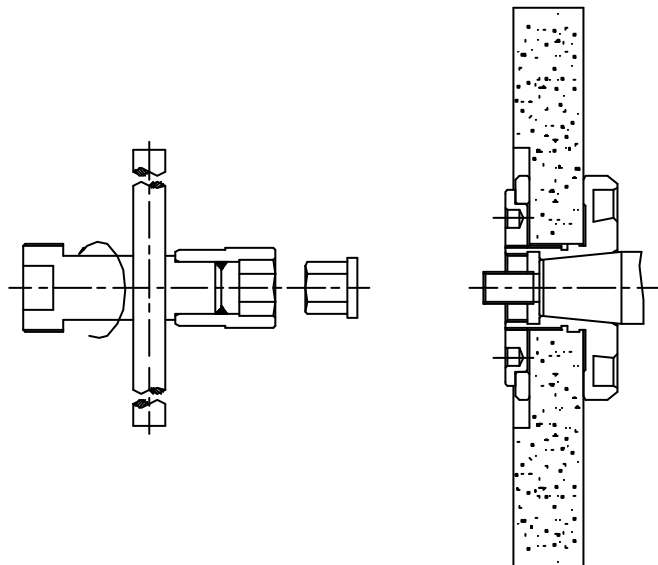



## 7-5 LOOSEN THE WHEEL FIXTURE

- (1) Turn off the power, wait until the wheel is complete stop, open the front cover and take out the locknut by turning it C.W.
- (2) Insert the picker into the wheel and rotate to release the wheel.

## 7-6 DRESS THE GRINDING WHEEL

Set the diamond on the dresser. The collar of the dresser is about 5 degrees. When the diamond becomes dull, turn the collar a small degree to maintain the cutting edge of the diamond sharp.

The surface finishes of the workpiece is concerned about the speed of the diamond passing through the wheel and the feed. The large feed and dressing the wheel faster will get a rougher surface of the grinding wheel. The smaller feed and dressing the wheel slower will get a more finishing surface of the grinding wheel.

We would suggest dressing the wheel 2 to 3 times. When dressing, start from the center of the surface of the wheel because the center is worn out slower than the side of the wheel. If dressing is started from the sides of the wheel, when the diamond nib reaches the center of the wheel face, the dressing amount will increase and cause the diamond jumping.

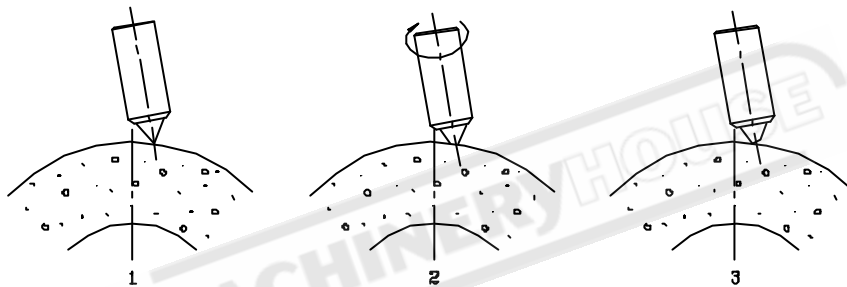

- ① The inclination angle between the new diamond and the wheel should be correct.
- ② The cutting point of the diamond become a flat surface, the collar must be turned for a small angle.
- ③ The new cutting point is as sharp as the new diamond now. After a certain period, the diamond should be replaced otherwise the diamond holder will be damaged, and the diamond will be thrown up.

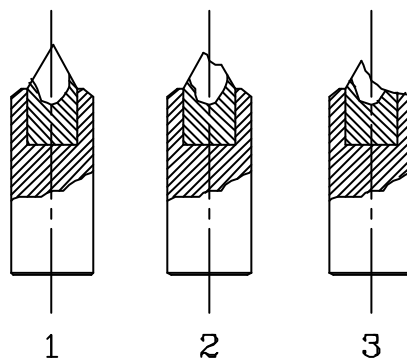

- ① New diamond.
- ② The diamond must be changed.
- ③ Too late: The diamond can not be changed because the holder can not hold the diamond tightly. Replace diamond and holder.

\* **Change the diamond only by an expert.**

## 7-7 GRINDING WHEEL RECOMMENDATION FOR SURFACE GRINDING

	Materials to be ground	Hardness	Wheel specification	
			under 8"	under 14"
Carbon Steel	Steel plate Carbon steel	under HRC 25	WA A 46K	WA A 46K
	Forging carbon steel Cast carbon steel	above HRC 25	WA A 46J	WA A 46J
Alloy Steel	Nickel chrome steel Chromium molybdenum steel High carbon alloy	under HRC 55	WA 46J	WA 46J
	Alloy cast steel Tool carbon steel Chromium steel	above HRC 55	WA 46I	WA 46H
	High speed steel	under HRC 60	WA 46I	WA 46H
Tool Steel	Alloy tool steel	above HRC 60	WA 46H	WA 46G
	Stainless steel		WA 46I	WA 46H
Stainless Steel	Autiheat steel		WA 36J	WA 30J
	Grey cast iron		C 46J	C 46I
Cast Iron	Special cast iron		GC 46I	GC 46H
	Malleable cast iron		WA A46K	WA A46J
	Brass			
Nonferrous Metal	Bronze			
	Aluminum alloy			
	Cemented carbide		GC 60-100 H,I	Diamond wheel
	Steel alloy		WA 46H	
	Glass porcelain		Diamond wheel	

## 7-8 TEST RUN

For safety, each wheel should be run freely for 5 minutes at least in its allowed speed or according to local regulations for testing run. When test running, stay away from the wheel especially on the left side of the wheel. Only use the wheel which has been tested.

### (1) Start the spindle

To actuate spindle, turn on the main power first. Press the “SB1” down to the bottom for power ON. Press the spindle switch “SB3”.

The spindle will begin to revolve. Check the direction of the rotation of spindle, if it is different from the indicator on the wheel guard, turn it off immediately.

### (2) Stop the spindle

To stop the rotation, press the spindle stop button “SB4” or power-off “SB2”. Press the Emergency Stop Button “SB0” only in case of emergency.

## 7-9 GRINDING WHEEL SAFETY RULES

1. Turn off the power before mounting or dismounting grinding wheel from the spindle.
2. Never operate a grinding machine that has no wheel guard equipped.
3. Never put your hands on working table or take off the work piece from the table until grinding wheel is completely stopped.
4. Make sure that the work pieces are firmly clamped on the work table.
5. Never try to use hands to hold or feed work piece.
6. Never grind the work piece which exceeded the table loading capacity and table working area.
7. Select correct grinding wheel, and keep the grinding wheel sharp.
8. While grinding, keep your hands or clothes away from work table.
9. Test each new grinding wheel for five minutes at its permitted rotating speed, keep away from danger zone while test running. The grinding wheel only can be used after this test running has been qualified.
10. It is necessary for the operator to wear a safety glasses and mouth mask.
11. Never exceed maximum safe operating speed of wheel.
12. Make sure that wheel guard has been well closed before starting the grinding wheel.
13. Do not grind the work piece too heavy that may slow down the spindle speed or increase heat on the work piece.
14. Carefully store grinding wheels in proper condition. They should be away from heat and humidity sources.
15. Make sure that the grinding wheel rotating direction must be in clockwise direction the same as the indicator on wheel guard.
16. Never alter hole in wheel or press too much force on wheel to the spindle.

## 8. CROSS MOVEMENT OF SADDLE

The mechanism to drive cross movement of the saddle either at -Z or +Z direction is a hardened lead screw and a self alignment feed nut. Rapid and selective moment is driven by an electrical motor.

### 8-1 SADDLE HANDWHEEL

Saddle motion could be done with this spring-loaded wheel manually.

Engage it with the lead screw by pushing in, and then rotate the desired saddle direction. Turn it clockwise to leave operator, while move counter-clockwise toward operator.



### 8-2 AUTO CROSSING STROKE ADJUSTMENT

Under the saddle, there is a setting device for saddle Stroke limit. Use this device(NO.1) to set grinding width.

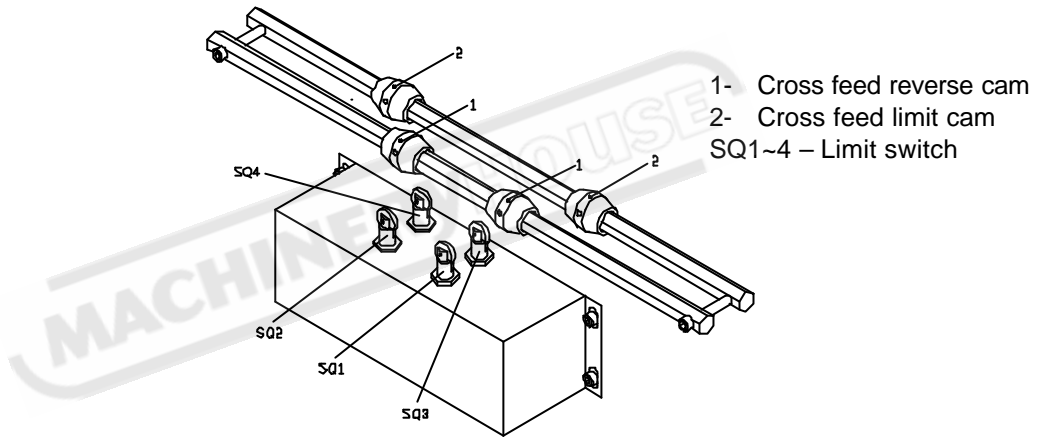
As precaution against over travel of the saddle, dead stops(NO.2) are employed. These are stops set by factory. Don't shift them unless in special case.



### 8-3 AUTOMATIC CROSS STROKE

Shift selection button (SA1) to  and push (SB11) or (SB12) to select cycle start direction. If the table is working, the automatic cross movement will operate at he reverse movement of the table. The moving distance can be set steplessly by otentiometer (RP1). The saddle will stop upon contacting the limit switch and follow the table to move reversly. The cross movement will stop by shifting the button (SA1) to .

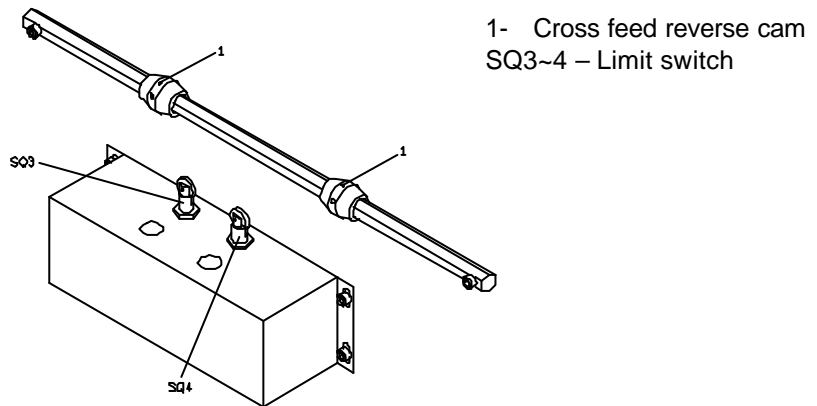

## 8-4 MICRO FEEDING (OPTIONAL)

Since small tolerance is required for many grinding operations, micro feeding on the saddle motion become necessary. This is achieved by using worm gear driven device. As follow, tighten the lock nut A to clockwise, then can starting the micro feeding.

Note: Before operating auto cross motion, disengage the lock nut counter-clockwise. When the lock nut is locking, the saddle can not be moved by the motor.

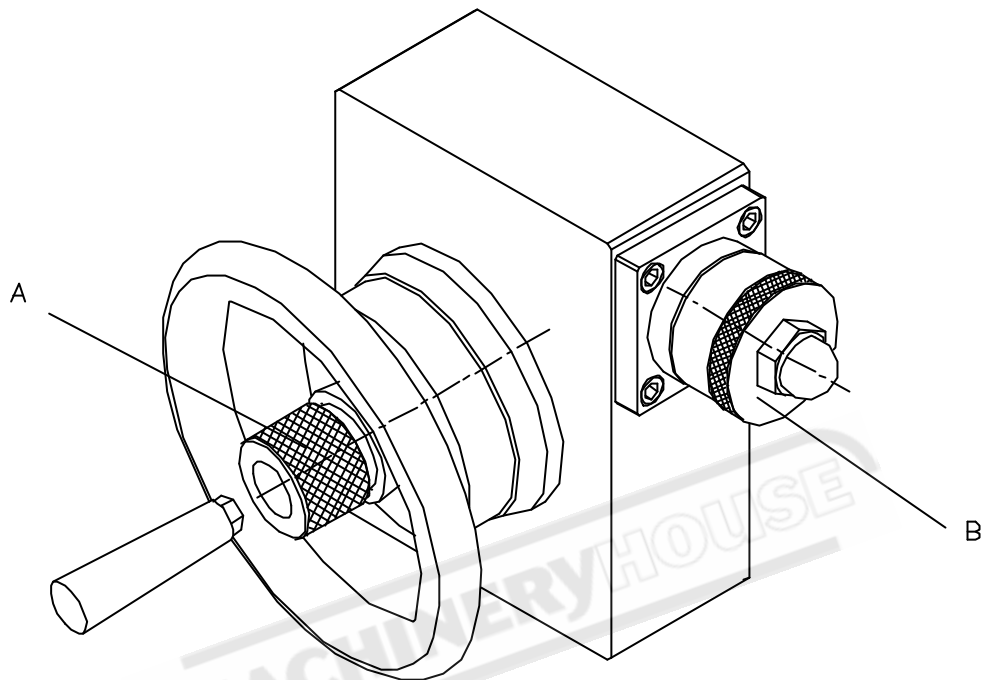

## 9. LONGITUDINAL MOVEMENT OF TABLE

The longitudinal -X and +X movement of the table are driven by the hydraulic system in the oil tank or using the handwheel. The control is fixed at the saddle.

### 9-1 TABLE MOVEMENT HANDWHEEL

The table movement could be done with this spring-loaded wheel manually. Engage it with the gear rack by pushing it, and then rotate for desired table motion. Turn it clockwise for the table will move toward the right, while counter-clockwise for the table, it will move toward the left.

## 9-2 TABLE REVERSING

The table will reverse automatically when the dogs hit the direction control arm. The stroke can be set by the two dogs which are positioned on the guideway.

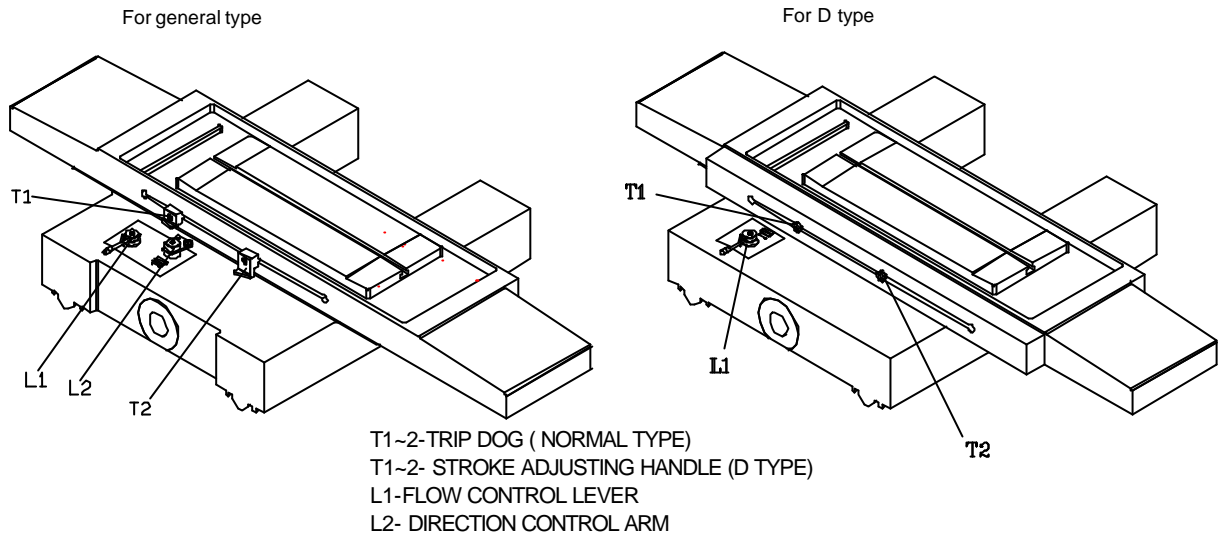

The table movement limits is adjusted by the two direction dogs with set screws. When grinding the smaller workpiece can adjust the two dogs to decrease distance or grinding the larger workpiece can adjust the two dogs to increase distance.

If the table dog T1, T2, fixed on the table T-slot bump against table directional arm L2 due to operator's neglect, L2 will slip out an angle from direction control shaft L3 and cause the table unable to travel automatically. In such case the remedy is as follows:

1. Turn L1 to close position to stop table moving. (pump is on)
2. Take away table dogs T1, T2 or move it apart from L2, this is for safety reason, for avoiding fingers from clamping by table dogs and L2.
3. Take off L2 and turn L3, make it "mark" at an position, then reset L2 on L3 make it at right position.
4. Turn L1 by left hand about 60 degrees for low table speed.
5. Turn L2 right and left (about 15-20 degrees) by right hand, if this can't make table move right and left, reset L2 at other position and try again turn L2 right and left, time after time you can find the right position for L3.
6. Loose L2 from L3 and reset L2 at it's right then fix it well on L3.
7. Doing this adjustment process, left hand control L1, right hand turn L2 simultaneously.
8. This is a troublesome work, and require patience to try again and again.

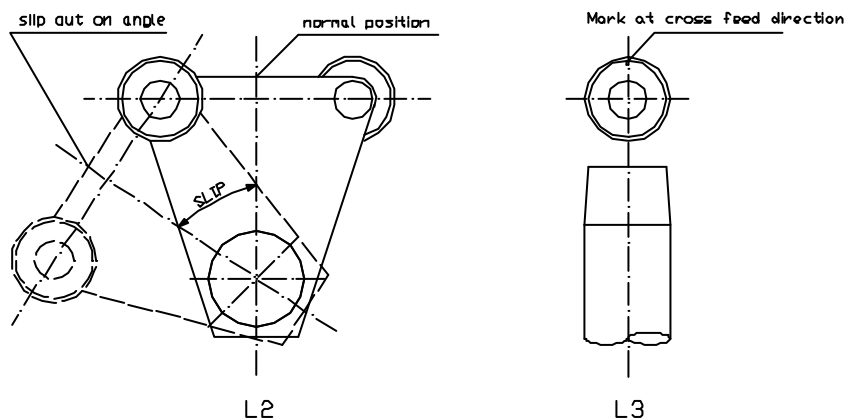

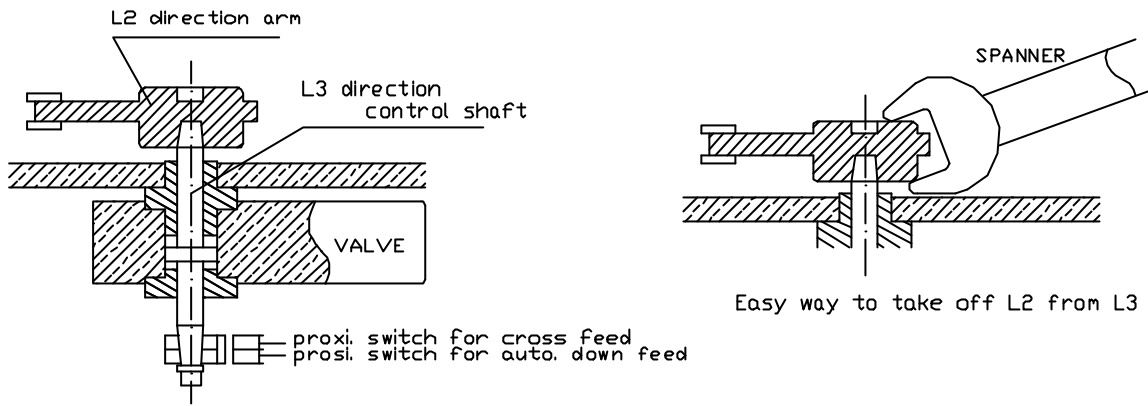

### 9-3 LONGITUDINAL MOVEMENT & SPEED CONTROLLING OF TABLE

(1) Start the table

Shift the magnetic switch (SA2) to . Adjust magnetic force through (RP2) to obtain the force not less than 50V which will be indicated in (PV1). Then press the hydraulic (SB3) button and machine is stand-by.

(2) Speed control

The speed adjusting is controlled by the lever. Turn the lever A clockwise continuously, to increase the table speed from 5m/min up to 25m/min. Table change direction by the B from the valves control.

**For General type**

**For D type**

A=SPEED CONTROL LEVER  
B=DIRECTION CONTROL ARM

A=SPEED CONTROL LEVER

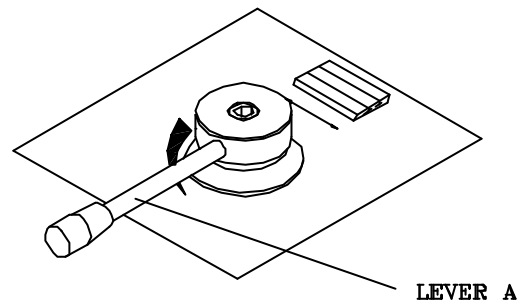
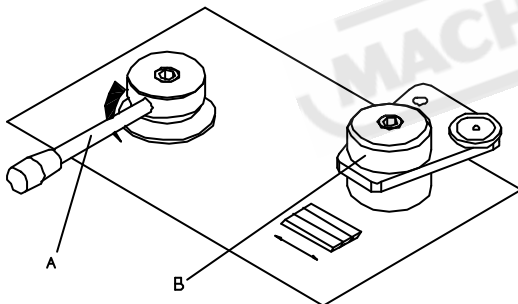

D type series: Before turning on hydraulic motor, please confirm if the speed control lever A is put on stop position. Otherwise, hydraulic motor can not be launched.

### 9-4 BLEEDING OF HYDRAULIC SYSTEM

The air existing in the hydraulic units will cause the table shock or slower reversing of the table. Run the table at maximum speed and stroke for at least 10 minutes to have the air bleed out.

### 9-5 DIAGRAM OF THE HYDRAULIC SYSTEM

For General type

For D Type

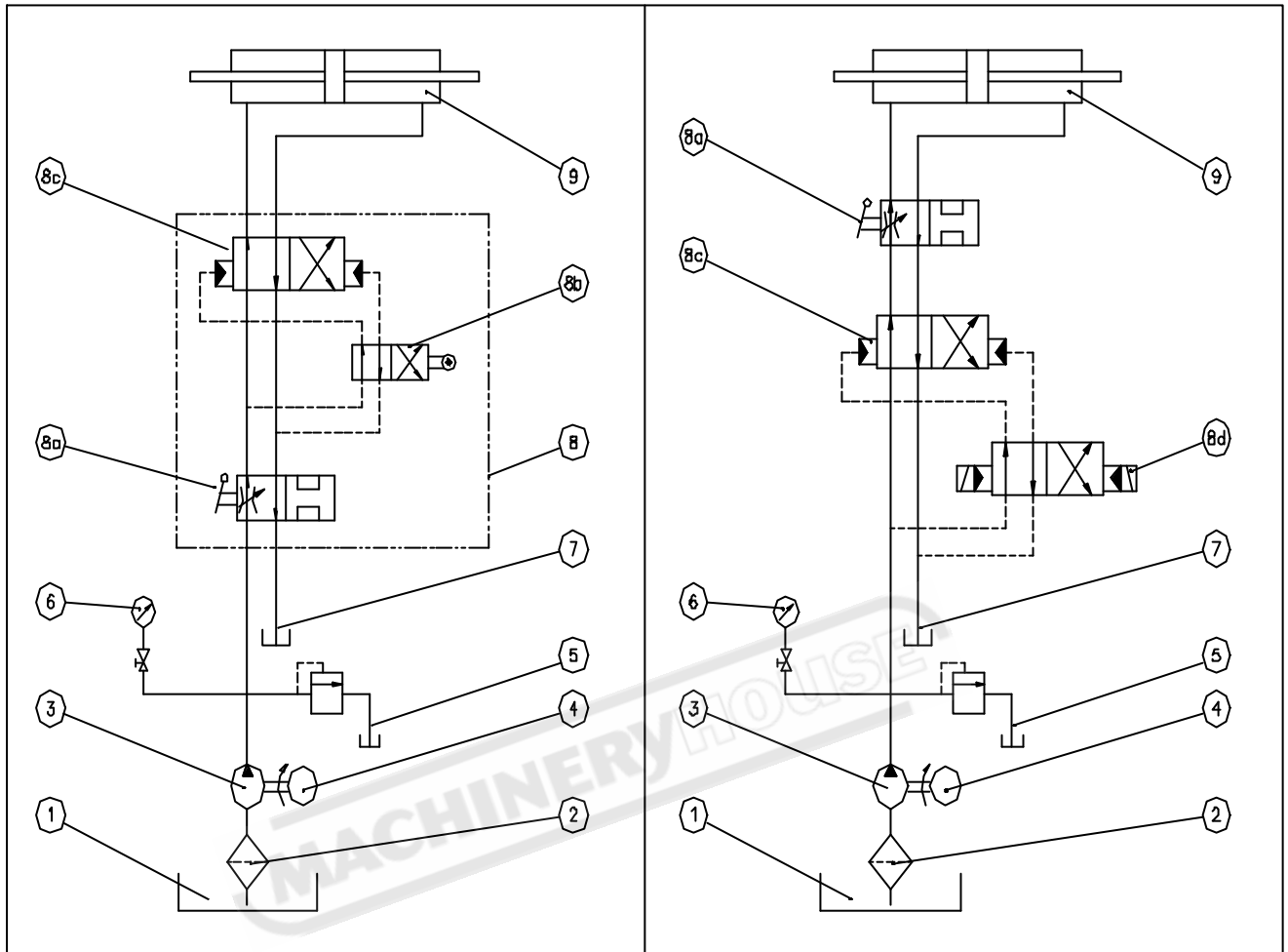

PART NO.	PART NAME
1	Oil tank
2	Oil filter
3	Hydraulic pump
4	Motor
5	Relief
6	Pressure gauge
7	Hose

PART NO.	PART NAME
8	Direction control valve
8a	Flow control valve
8b	Pilot valve
8c	Main spool chamber
8d	Solenoid valve
9	Cylinder



### 9-6 INTRODUCTION OF THE HYDRAULIC TANK

FOR C1545~C3060

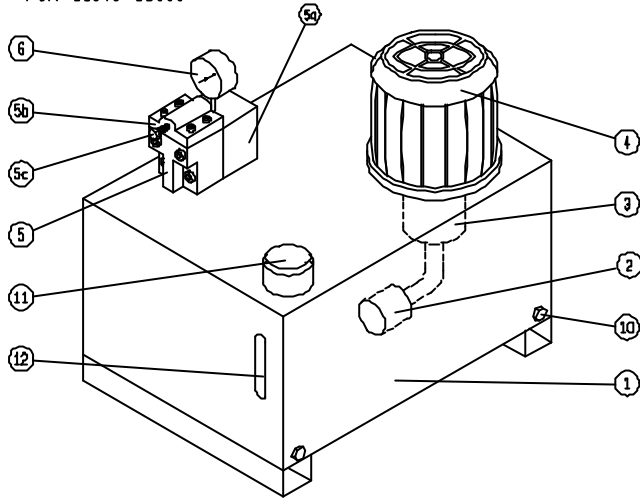

FOR D2550~D3060

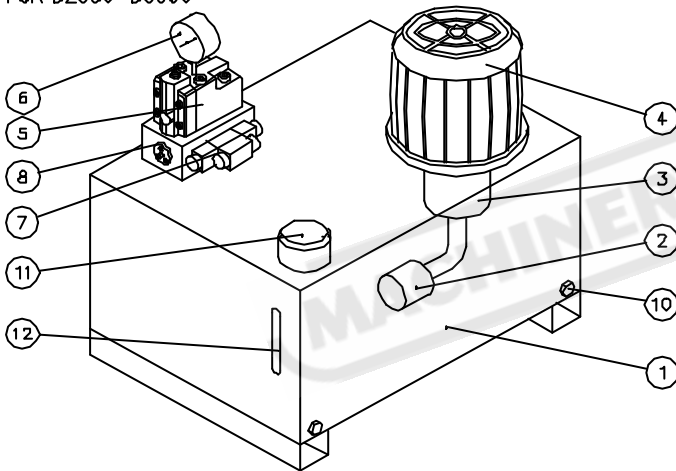

FOR D4080

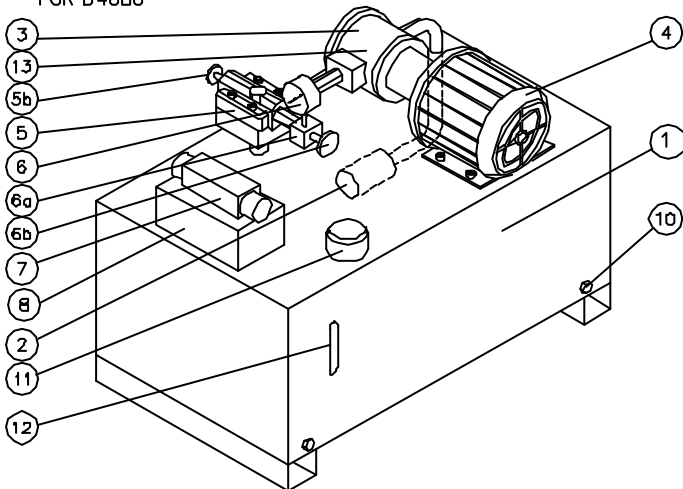

No.	Description
1	Oil tank
2	Filter
3	Hydraulic pump
4	motor
5	Relief valve
5a	Oil road valve
5b	Pressure regulating
5c	Leveling screw
6	Pressure gauge
6a	Pressure gauge valve
6b	Pressure gauge knob
7	Solenoid valve
8	Direction valve
10	Oil drain hole
11	Filling oil hole
12	Oil gauge
13	Coupling (inside pump)

## 10. VERTICAL MOVEMENT OF WHEEL HEAD

The movement of wheel head at +Y/-Y direction is driven by an elevating leadscrew.

### 10-1 MANUAL OPERATION

Turn the wheel clockwise to down the wheel head, that is move in -Y direction, or counter-clockwise to down the wheel head, that is move in +Y direction. There are 200 Metric graduation with 0.01mm/gradation and 2mm/rotation.

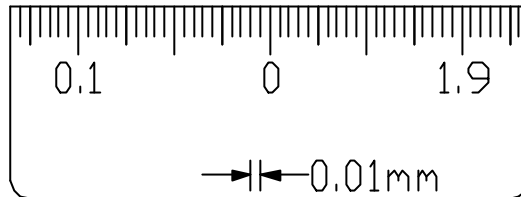

### 10-2 MICRO FEED FOR VERTICAL (OPTIONAL)

General operation is the same to cross micro feed. The minimum gradation is 0.001mm(0.0005").

### 10-3 POWER RAPID WITH MICRO FEED FOR VERTICAL (OPTIONAL)

The micro feeding operation is same as previous. If using the rapid movement, machine must be disengaged the lock nut counter-clockwise, than can push the (SB28),(SB29)simultaneously to descend (-Y) the wheel head. Or push the (SB30) button, the wheel head will ascend (+Y).



**Caution:** Before operating rapid descending of the head wheel, machine must be disengaged the lock nut, otherwise it will damage in your rapid motor.

### 10-4 RAPID ASCENDING/DESCENDING OF WHEEL HEAD (OPTIONAL)

Pushing the button (SB30), the spindle will ascend (+Y). To descend the spindle, the connecting switches (SB28) and (SB29)must be simultaneously. Erroneous switching on will cause the head wheel to descend unexpectedly to damage the workpiece.

## 11. AUTOMATIC DEMAGNETIZATION

Operating procedures for electromagnetic controller (optional accessory).

1. Excitation: Position the selection switch SA6 at  for excitation. The indicator PV1 will light at the RP2 voltage value.
2. Magnetic force adjusting: This can be carried out by adjustment switch PR2.
3. Stop: Shift switch SA6 to . Wait for demagnetization to prevent risks.
4. Demagnetization: Position SA6 to  to start demagnetization. The RP1 can control demagnetize times to release the workpiece.

## 12. CHECK BEFORE GRINDING OPERATION

1. Make sure the machine is clean and level.
2. Check the hydraulic oil in the tank. It must be filled up to the red line of oil meter.
3. Make sure the spindle revolving direction is same as the indicating arrow on the wheel guard.
4. Make sure the velocity and specifications of grinding wheel conformed to the requirements of wheel manufacturer.
5. Make sure of the safety of grinding wheel properly secured on the spindle.
6. Make sure magnetic chuck is securely held on table.
7. Preset the stroke of table and saddle according to size of workpiece.
8. Loose the saddle lock device for the saddle to move.
9. The magnetic chuck switch SA6 is positioned at the middle which stops the hydraulic pump motor and spindle switch is at OFF.
10. Check for all switches positioned at "OFF" and "⏏".

## 13. OPERATION TESTING

For a new machine or restart of the machine after disconnection of power supply during operation, all the switches should be shift to "OFF" or "⏏". The procedure should follow as below:

1. First, connect the power line to the electric cabinet.
2. Using handwheel, drive the saddle and wheel head to check for smooth movement.
3. Turn on the main power switch on the door of electric cabinet.
4. Clockwise turn the emergency stop switch SB0 to disengage it.
5. Push the SB10 button to check the saddle movement is correctly. If do not, change any of the two power line any two wire.
6. Push the SB1 button, the SB1 lamp will be lighten than can ready to work.
7. Push the SB7 button to check the coolant system is working.
8. Push the SB5 button to check the hydraulic system motor direction is correct.
9. Push the SB3 button to check the spindle motor.
10. Set stroke of saddle and table. (refer to the P. B-15)
11. Shift magnetic switch SA6 right to . The magnetization indicating lamp PV1 lights immediately.
12. Turn RP6 increase to adjust magnetic force to 50V at least, which will be shown on PV1.

## 14. GENERAL OPERATION MODE

### I. Management on Emergencies

1. Press "Emergency Stop Button" (SB0) at once when emergency occurs.
  2. Disconnect power, if emergency still exists.
- Refer to maintenance manual or contract service technician for solution.

## II. Manual Plane Grinding Operation

1. Shift the main power switch to position "1".
2. Disengage "Emergency Stop Button" SB0.
3. Press push button SB1, indicating lamp lights and control power on.
4. Push button SB5 to actuate spindle motor. (It can start only after closing the wheel's cover)
5. Push button SB6 to stop spindle motor.
6. Start hydraulic motor:
  - (1) Shift selection switch SA6 to the position of magnet. Adjust Knob RP6 (at clockwise to increase or at counter-clockwise to reduce). Voltage can be read from the voltmeter PVI. (The voltage must be over 35V to start hydraulic motor.)
  - (2) Counter-clockwise turn the hydraulic throttle valve to the extreme, then push button SB3 to start hydraulic motor.
  - (3) Clockwise turn the hydraulic throttle valve to start cross movement of table.

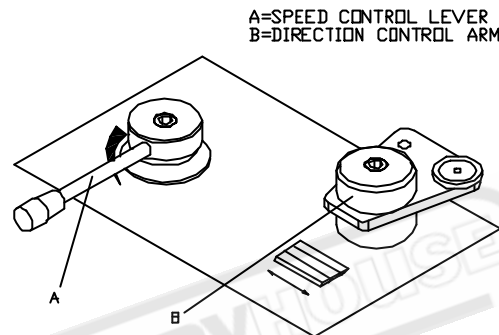

7. Stop hydraulic motor:
  - (1) Counter-clockwise turn the hydraulic throttle valve to the extreme, then table stops moving.
  - (2) Push button SB4 to stop hydraulic motor.
8. Push button SB7 to actuate motor of coolant system.
9. Push button SB8 to stop motor of coolant system.
10. Rapid movement of Z-axis:
  - (1) Shift the mode selection switch SA5 to manual position.
  - (2) Push button SB10 for the table to move forward rapidly.
  - (3) Push button SB9 for the table to move backward rapidly.
11. Rapid movement of Y-axis:
  - (1) Shift the mode selection switch SA1 to manual position.
  - (2) Push button SB11 for the spindle to move upward rapidly.
  - (3) Concurrently push both button SB28 and SB29 for the spindle to move downward rapidly.

## III. Semi-Automatic Plane Grinding Operation

1. Shift the main power switch to position "1".
2. Disengage "Emergency Stop Button" SB0.
3. Press push button SB1, indicating lamp lights and control power on.
4. Place workpiece on the table. Shift selection switch SA6 to the position of magnet so as to clamp the workpiece with magnetic force. Adjust Knob PR6 (at clockwise to increase or at counter-clockwise to reduce). Voltage can be read from the voltmeter PV1. Adjust proper cross and longitudinal stroke of table. (The voltage must be over 35V to start hydraulic motor)

5. Shift selection switch SA1 to manual position. Concurrently push both buttons SB28 and SB29 for grinding wheel to move near the workpiece and press button SB5 and SB7 to start spindle and coolant system.(It can start only after closing the wheel's cover)
6. Counter-clockwise turn the hydraulic throttle valve to the extreme,then push button SB3 to start hydraulic motor.Slowly turn the hydraulic throttle valve at Clockwise,table will operate longitudinal movement repeatedly.
7. Turn the hand wheel to feed and till grind wheel getting to workpiece.
8. Shift switch SA1 to automatic mode,press button SB9 or SB10 to start program operation.
9. Adjust cross feed Knob RP7.(clockwise to increase or counter-clockwise to reduce cross feed)
10. Perform plane grinding by Semi-Automatic feed operation till the workpiece reaches desired requirements.
11. Counter-clockwise turn hydraulic throttle valve to the extreme to stop table movement. Shift switch SA1 to manual position to stop the program.
12. Push button SB6 and SB8 to stop spindle and hydraulic system.
13. Shift switch SA6 to demagnetization position. After demagnetization, remove the workpiece.
14. Repeat procedures 4 to 14 for another plane grinding operation.

## 15. MAINTENANCE

### 15-1 CAUTIONS

1. Make sure the main power of the machine has been turned off and the machine has complete stopped before starting maintenance service.
2. Clean the table with soft cloth at the end of daily operation.
3. Prevent dust and chips from entering into guideways.
4. Avoid of any abnormal maintenance.

### 15-2 LUBRICATION

Drawing diagram: FOR 1545M~2045M

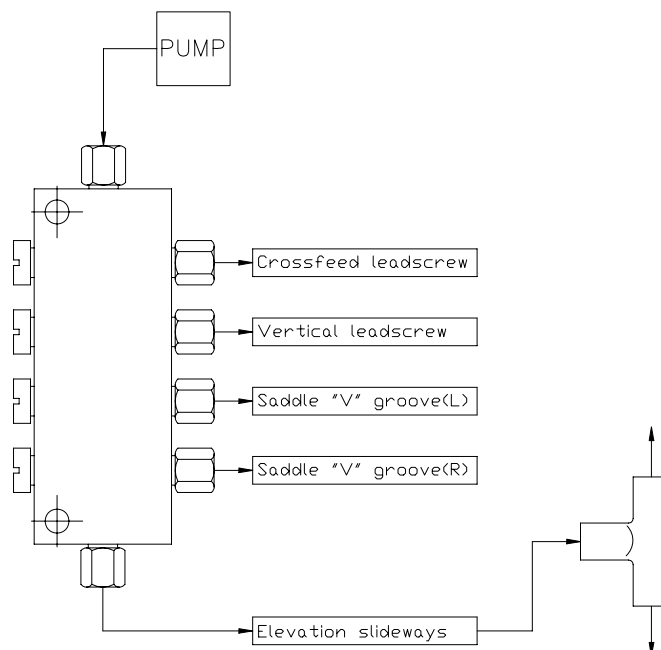

### FOR 1545 2045 2550 D2550 C3060 D3060

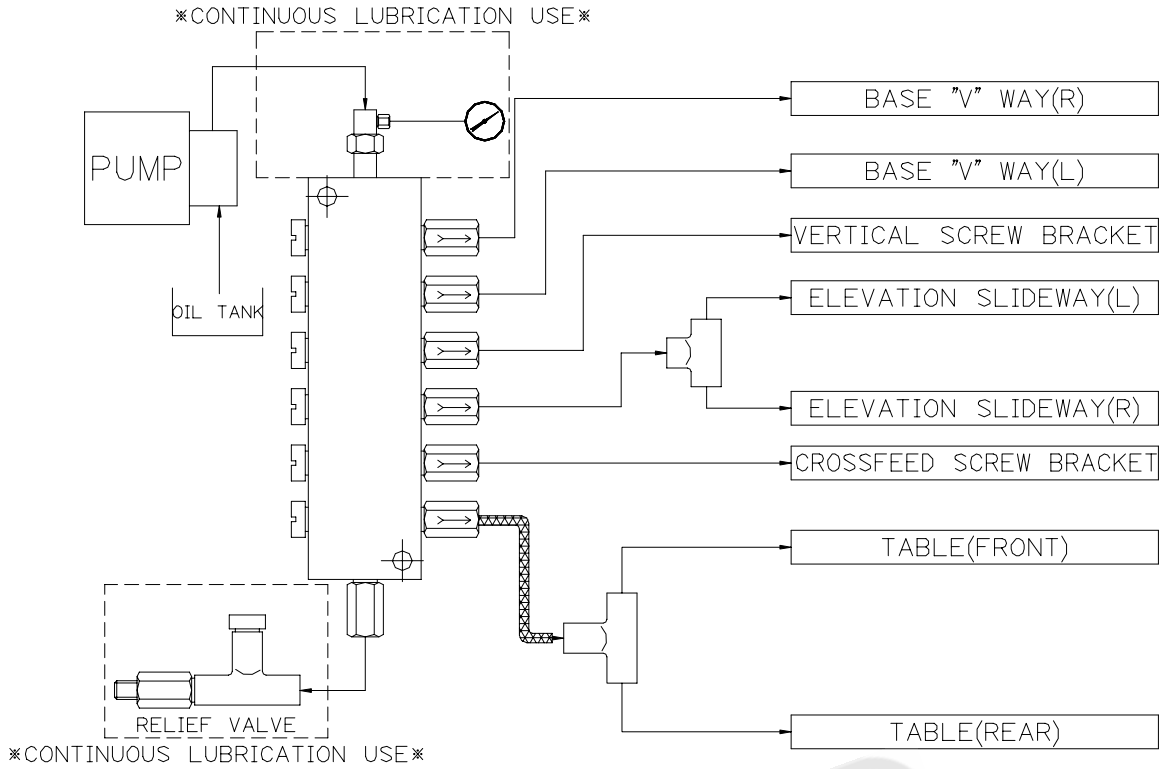

### FOR D4080

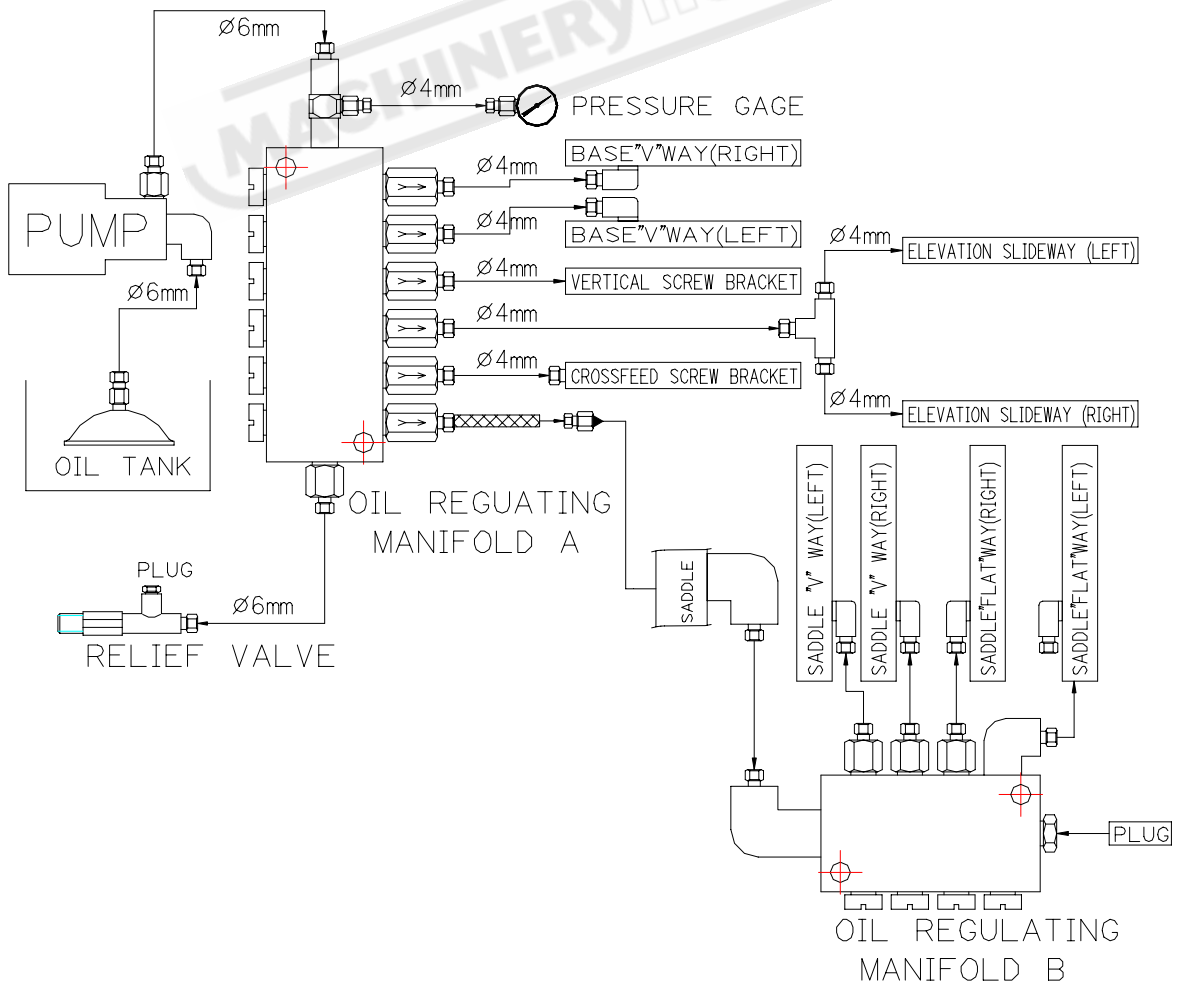

Check lubricant level daily for sufficient lubricant supply. Check tubes for free flow. Reliability of the machine and economic running are ensured only by the correct choice of lubricant for the individual lubricating points.

1. Lubrication pump:

- 1-1 For General type: Auto. lubrication pump will be operated when machine power is ON, then pump 3-6mm<sup>3</sup> (adjustable) in every 15 minutes.
- 1-2 For D type: A forced circulation oil system is used to lubricate whole machine to maintain the accuracy and extend life time of gliding surface and transmission system.

2. Lubricant: ESSO-FEBIS K68, MOBIL-VACTRA 2, SHEEL-Vactra Or same as ISO 68 standard lubricant. Units: Liters

MODEL	2550AH	3060AH	D4080AH
CAPACITY	2 (15min/time) 7 (continuous-option)	2 (15min/time) 10 (continuous-option)	19 (continuous)

### 15-3 MAINTENANCE OF HYDRAULIC SYSTEM

The purpose of maintenance is keeping the hydraulic system doing job, and it must be done exactly and quickly by taking the less time. So we can not neglect the maintenance and inspection of hydraulic system on the daily work.

#### 15-3-1 MAINTENANCE OF THE OIL TANK

- (1) Make sure the oil level always in the standard range.
- (2) Use the temperature gage to check weather the oil temperature is still in the suitable temperature for working or not. The temperature which is near to the suction inlet of the pump can not over 55°C.
- (3) Do not take off the filling sieve when filling the oil.
- (4) The bottom of the oil tank must be drained periodically.
- (5) Inspect the quality of the oil every two or three months.
- (6) The wasted oil should be disposed by special treatment procedures to prevent pollution.

#### 15-3-2 MAINTENANCE OF THE PUMP AND THE SIDE OF THE SUCTION INLET

- (1) The filter which is in the side of the suction inlet should be cleaned by using the kerosene or light oil and blowing the inner of the filter each two or three month.
- (2) Be careful the connector (union socket, elbow) of the suction system and pump, because the looseness will make the air enter the system.
- (3) Use the pressure gage to confirm whether the bleeding pressure is correct or not.

#### 15-3-3 MAINTENANCE OF THE CONTROL VALVE

- (1) The adjusting screw of the pressure valve should be checked every a half year. Tune the pressure to be is smoothly while adjusting the screw.
- (2) The screws of the direction control valve are loosen because of the striking of reversing should be checked every a half year.
- (3) The flow rate control valve (table speed control valve) should be checked every year. Sometimes, the table is still moving when the control valve has been set at home point.

### 15-3-4 MAINTENANCE OF THE OUTER CONNECTOR

For a new machine, check all the connectors for leakage after the first 50 operating hours. Further inspection shall be taken every 200 operating hours.

### 15-4 CLEANING OF COOLANT SYSTEM AND DUST SUCTION SYSTEM

Please refer to the operating manual attached with coolant system and dust suction system.

#### 15-4-1 SELECTION AND FILLING OF COOLANT

It is recommended to use clear heavy coolant of high-pressure performance to prevent from generating bubble. For filling coolant, add 1/3 clean water to the tank first, then pour in the coolant of desired volume and add water again to be full of the tank, evenly mix the mixture. The mixing ratio 1:60 to 1:80 is acceptable.

#### 15-4-2 CAUTION FOR USE OF COOLANT

1. Professional allergy generally caused by the following reasons:
  - (1) Skin is not cleaned completely with oil remaining on it. (Wash hands and arms after work to prevent this trouble.)
  - (2) Skin is affected and chapped by the coolant with chemical /cleaning nature.
2. Dispose of the used coolant should be based on local waste water treatment regulations before drainage to avoid pollution.

#### 15-4-3 MAINTENANCE OF THE SUCTION DEVICE

1. Please clean dust collection cabinet from time to time.
2. Please also clean the housing of the motor. When clean the dust collection cabinet.

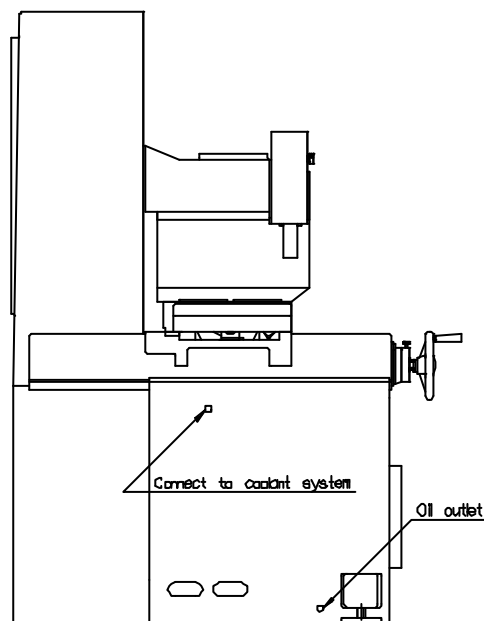



## 16. TROUBLE SHOOTING

### 16-1 Grinding NO.1-NO.6

NO.	Defects	Cause	Remedy
1	Chatter marks usually caused by vibration in the machine itself.  The machine does not run free from vibration	Machine foundation is not firm enough.	Improve the foundation.
		The leveling screw in machine base are loosen.	Tight and lock them.
		Work table does not run smoothly.	See item NO.8.
		Table not fully supported.	Re-scrap the contact surfaces of table and bed sideways.
		Grinding wheel does not sit firmly on the wheel flange.	Replace the washer between wheel and flange, tighten them well.
		Flanges does not fit firmly on the grinding spindle taper nose.	Clean both taper contact surfaces make sure they are well contacted and fitted firmly.
		Wheel and flange are not well balanced.	Balance them well again.
		Wheel is unhomognerous.	If wheel and flange can not be well balance, dress wheel on periphery and both sides and balance it again. If one can't make it balanced, replace a new wheel.
		Use improper wheel.	Select a proper one to suit the workpiece material.
		Wheel is not dressed correctly.	The dressing diamond must be turn an angle or replace a new one if it is not contacted wheel with an edge diamond tool not firmly fixed.
		Too much pressure on the grinding spindle.	Re-adjusting the spindle pressure by qualified technician.
		Vibrations transferred to machine from outside, such as rough- running machine, traveling cranes of the building and street vehicles.	Improve the foundation, to make it vibration free, or place machine to another vibration free position.
Coupling of motor and spindle is loosen or rubber broken.	Fix couplings well, or replace a new one.		

NO.	Defects	Cause	Remedy		
2	Flutter mark appear in the front of small flat surface distributed over the surface of the workpiece unevenly.	Unsteady running of grinding wheel.	3 Phases voltage of power source are unbalance, please check and balance it or replace a new spindle.		
		Stroke removal too much.	Reduce infeed. Reduce cross feed.		
		Grinding wheel too hard or dull.	Use softer or coarser wheel. Increase table speed. Reduce infeed. Roughen the wheel. Check diamond of the dresser.		
			Traveling cranes or hoist of the building.	Improve the foundation. Change the position.	
				Traveling vehicles in the building or street.	Use anti-vibration plates.
			3	Ray pattern parallel lines, hardly perceptible to the naked eye.	Grinding spindle bearings have defects.
		Too much pressure on wheelhead guide way.			
Wheel badly dressed.					
4	Commas-haped lines appeared when grinding to get precision finish.	Coolant too dirty.	Clean coolant or use automatic paper scrip filter.		
		Grinding wheel chips off.	Clean inside of the wheel cover. Choose proper wheel.		
5	Burn marks and grinding cracks caused by intense local heating of the workpiece.	Grinding wheel too hard.	Use softer or coarser wheel. Increase table speed. Reduce peripheral speed of wheel.		
			Grinding wheel is dull or clogged.	Dress the wheel make it roughen and bit better.	
			Stock removal too great.	Reduce infeed. Reduce cross feed.	
		Table speed too low.	Increase table speed.		
		Inefficient cooling.	Increase coolant. Use stronger mixture coolant (fill up with fresh oil).		
			6	Grinding spark abnormally.	It can not be "spark out".

16-2 Operation NO.7-NO.13

NO.	Defects	Cause	Remedy
7	Worktable can not start.	The electric magnetic chuck does not switch on, so that pump motor does not work.	Switch on the chuck or automatic demagnetizer switch if it is used on the machine.
		Over load relay of pump motor cut off the magnetic switch, so that pump motor does not work.	Push reset lever of the over load relay.
		Oil pump can't deliver oil.	Check motor direction is wrong or not. Fill in oil from "P" port, then switch on pump motor.
		Turn clockwise the "Table longitudinal control lever" to it's open position, the table still can't start.	Open and close lever several times if still doesn't start, regulate the relief valve and increase the pressure.
8	Worktable doesn't run smoothly.	Use improper hydraulic oil.	Mobil vacuole #1409 or it's equivalent is recommended.
		Table speed are different at right and left direction, due to direction Arm L2 lose it's right position.	Adjust direction Arm L1 refer to the page 16.
		Hydraulic pump does not deliver sufficient oil level is too low.	Top up hydraulic oil.
		Suction filter is dirty and clogged.	Change the oil, clean the filter.
		Air leave in the cylinder.	Start work table at slow speed with full stroke and stop a little while at both ends, repeat these processes several times
9	Worktable can not reverse and runs to one side.	Directional arm L2 slip out from Directional control shaft L1	Refer to page 16.
10	All function except SA2 do not work.	Fuse on Tc.1(FU9) is broken.	Replace new one.
		Wire of control circuit 24V loosen from use terminal 1, 2.	Fix the wire well.
		Transformer Tc.1 defect	Replace new one.

NO.	Defects	Cause	Remedy
11	Auto. cross feed does not function	Motor control unit (M.C.U) has defect.	Check terminal of this unit as follows: 1.Short 16,17 by a wire. 2.Check voltage of L23, L33 it must be 220V (+10 % ) if not it means this unit is out of order. 3.Push SB10 or SB9 check the motor is reversing. (If not reversing, the M.C.U is defective.)
		The limits SW. SQ3~4 for max stroke safety control is presses or defective. (refer to page 14)	Check SQ3~4 repair or replace new one.
		Proximity switch for cross feed has defect or can't be engaged by direction cam 251646.	Fix it, or replace a new one.
		Wheel head locking device (if any is engaged.)	Disengaged the locking device.
12	Auto. cross feed does not reverse, and runs to one direction.	Limit switch LS1, LS2 for stroke adjustment is defective or trip dog loose and can't control LS1, LS2.	Fix trip dog well and change new limit switch if necessary.
		Magnetic contractor for cross feed motor does not function.	Check wether the contractor coil is loose or not. Check wether the contractor coil is burnt out or not if so replace new one.
13	Magnetizing does not work.	Fuse(FU10) is broken.	Replace new one.
		Transformer Tc.1 defect.	Replace new one.
		The switch SA6 is defect. (take off the magnetic chuck wire form terminal C1, C2)	1.Turn SA6 to right position (magnetizing) Check terminal C1, C2 it's must be D.C voltage. 2.Replace a new one.
		Electric magnetic control defect.	Check terminal of this unit is follows: 1.Check voltage of wire NUM.103 104 must be AC 110V, if not it means FU10 broken or Tc.1 is defect. 2.Replace new one.

## 17. USE OF THE OPTIONAL ATTACHMENT

### 17-1 PARALLEL DRESSING ATTACHMENT

The wheel can be dressed either by diamond tool on the chuck or on the parallel dressing attachment which mounted on spindle carrier. The diamond tool is arranged at an angle on the center line of the wheel as shown on Figure, so that when the diamond loses its keenness it can be turned an angle, ensuring that there is always a sharp diamond edge available. The dressing method and points are same as "Dressing the wheel". Experience has shown that, with highly accurate grinding, dressing with the diamond which mounted on the magnetic chuck is better than which on the spindle carrier (the former is more stable than latter) as the latter condition will cause slight undulation in the surface of the wheel.

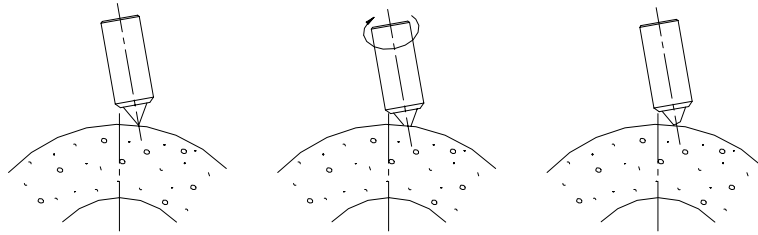

### 17-2 ANGLE FORMING ATTACHMENT

- (1) Let the attachment be attracted to the magnetic chuck, keeping a 90° right angle between the attachment and the wheel. The magnetic chuck should be kept level.
- (2) The value in question will be the sine of the angle times 50. That is  $B = \sin \theta \times 50$ .
- (3) Get a block gauge the thickness of which equals that of B (or make one).
- (4) Put his block gauge under the base of the Sine Bar stand. Fix with the fastening bolts and the forming is done.

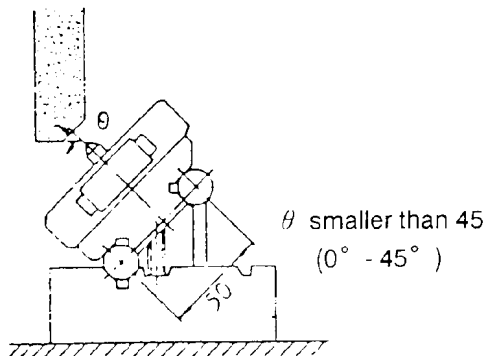
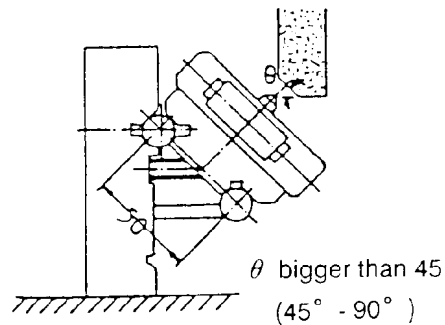
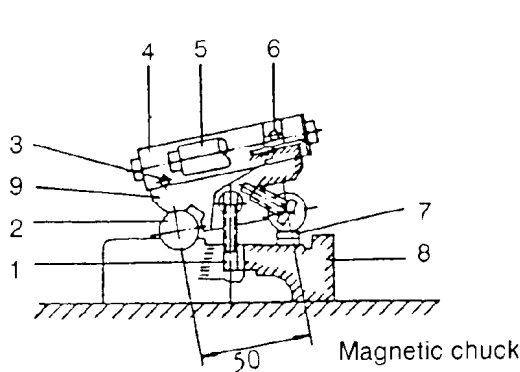

1. Fastening bolt
2. Mandrel
3. Slide adjustment bolt
4. Slide base
5. Handle
6. Diamond fixed hole
7. Block gauge
8. Build-in base
9. Sine Bar stand

(5) Degree and block gauge thickness conversion table.

Deg.	Sin.	Block gauge thickness	Deg.	Sin.	Block gauge thickness	Deg.	Sin.	Block gauge thickness
1°	0.0175	0.875	16°	0.2756	13.780	31°	0.5150	25.750
2°	0.0349	1.745	17°	0.2924	14.620	32°	0.5299	26.495
3°	0.0523	2.615	18°	0.3090	15.450	33°	0.5446	27.230
4°	0.0698	3.490	19°	0.3256	16.280	34°	0.5592	27.960
5°	0.0872	4.360	20°	0.3420	17.100	35°	0.5736	28.680
6°	0.1045	5.225	21°	0.3584	17.920	36°	0.5878	29.390
7°	0.1219	6.095	22°	0.3764	18.730	37°	0.6018	30.090
8°	0.1392	6.960	23°	0.3907	19.535	38°	0.6157	30.785
9°	0.1564	7.820	24°	0.4067	20.335	39°	0.6293	31.465
10°	0.1736	8.680	25°	0.4226	21.130	40°	0.6428	32.140
11°	0.1908	9.540	26°	0.4384	21.920	41°	0.6561	32.805
12°	0.2079	10.395	27°	0.4540	22.700	42°	0.6691	33.455
13°	0.2250	11.250	28°	0.4695	23.475	43°	0.6820	34.100
14°	0.2419	12.095	29°	0.4848	24.240	44°	0.6974	34.735
15°	0.2588	12.940	30°	0.5000	25.000	45°	0.7071	35.355

\* The value of block gauge thickness must times 2 when apply this table to Sine Bar attachment.

17-3 SINE BAR

The Sine Bar is used to chuck the inclined angle of the magnetic chuck, when the angle forming surface is large.

- (1) The value in question equals the Sine of the angle times 100,  $B = \sin \theta \times 100$ .
- (2) Get a block gauge the thickness of which equals that of B.
- (3) Put this gauge at one end of the Sine Bar and let it be attracted to the inclinable magnetic chuck, This Sine Bar shall be kept parallel to the longitudinal direction of the machine
- (4) Press the dial gauge against surface of the Sine Bar and meanwhile turn the cross feed hand wheel. so that the saddle moves back and forth for the checking of the accuracy of the angle of the magnetic chuck.

- |               |                                   |              |
|---------------|-----------------------------------|--------------|
| 1.Mandrel     | 4.Application of the trigonometry | 7.Stop block |
| 2.Sine Bar    | 5.Inclinalb Magnetic Chuck        |              |
| 3.Block gauge | 6.Mandrel of the Magnetic Chuck   |              |

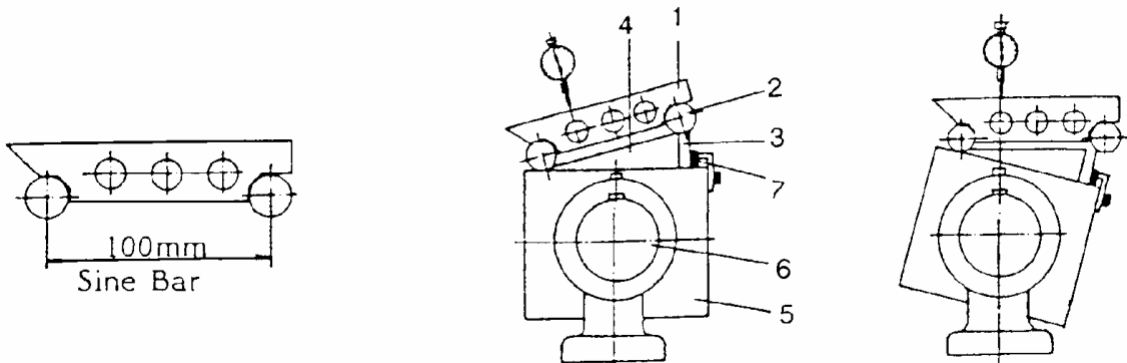

### 17-4 RADIUS FORMING ATTACHMENT

The Radius Forming Attachment is composed of a main stand, several swing rods and a diamond tool.

(1) Main Stand

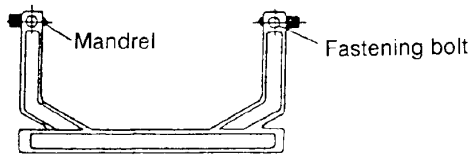

(2) Swing rod and diamond Tool

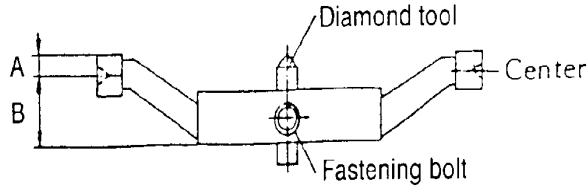

A name plate is attached to the swing rod with the A and B to mean:

a: the distance between the upper rim and center.

b: the distance between the bottom rim and center.

The R forming is the adjustment of the distance between the diamond tool and the swing rod center so that R shaping results.

(3) To determine the concave and convex R:

a. If the tool is parallel to the center line, it equals OR.

b. To determine the convex R: Put the swing rod on a place disk. Put a block gauge of proper thickness under the diamond tool. Then  $R = X - A$ .

c. To determine the small concave R:  $R = A - X$

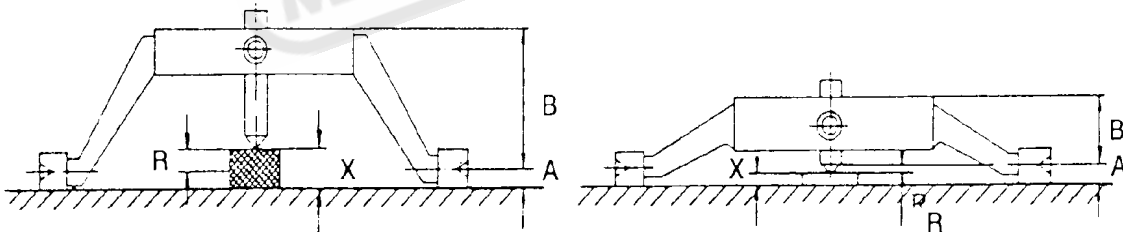

d. To determine the big concave R:  $R = B + X$

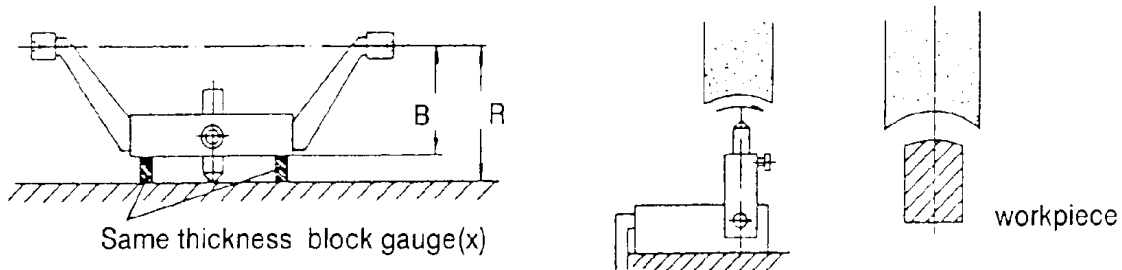

e. Note:

1. The base and side of the grinding wheel shall well-dressed.
2. The Radius Forming Attachment shall be parallel to the grinding wheel.
3. The diamond tool shall be parallel to the Radius Forming Attachment.

(4) Operation of the Radius Forming attachment:

a. Find the center of the grinding wheel, then fix the work table.

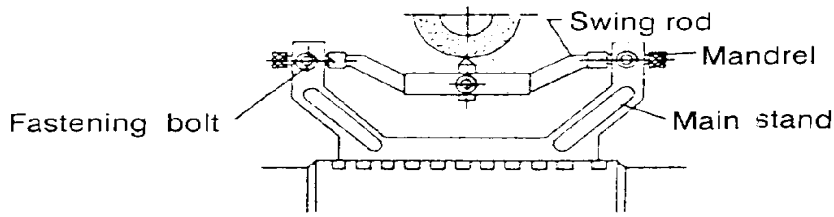

b. Turn the down-feed handwheel at 1/3 on the width of the wheel so that the wheel cuts into 0.02mm of the diamond tool. Now turn the cross feed handwheel to dress the grinding wheel, and turn the calibration reading on the down feed back to zero.

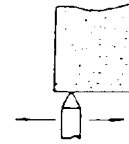

c. Turn the diamond tool over an angle 90° and elevate it into a proper position (greater than the R size in question).

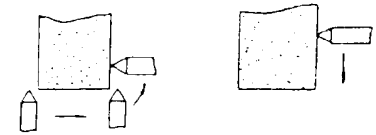

d. Elevate the grinding wheel so that it goes away from the diamond tool and wheel in such a position that the distance between the side of the wheel and the center of the diamond tool is just R.

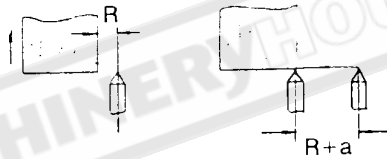

e. Move the diamond tool (R+a) leftward, with "a" found in the following table.

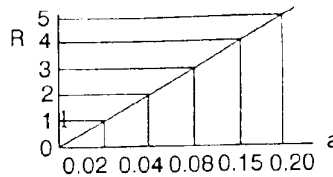

f. Turn the downfeed handwheel so that the grinding wheel approaches the diamond tool.

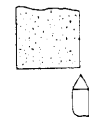

g. Turn the swing rods 90° each time, inching 0.05mm till the R is determined.

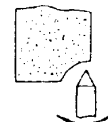

h. The wheel finally becomes the following shape.

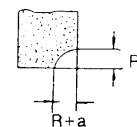



17-5 COMMON CASES IN SIDE GRINDING

- (1) In the cases shown in the figure above, the side-grinding wheel and work have a smaller contact surface, in which case the efficiency is higher, and the surface roughness is better.



- (2) In the figure above, the wheel and the work have two sections of contact, and the surface of grinding is bad. The surface has to be corrected into the shape shown in (1).

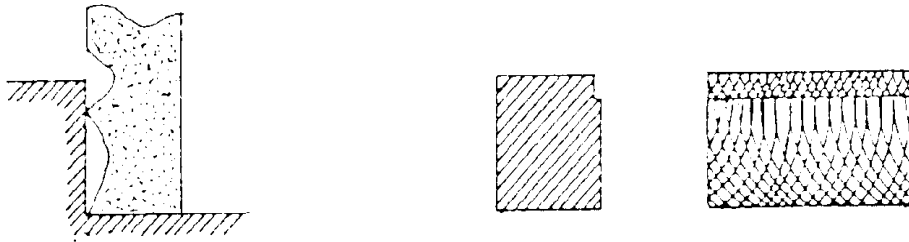

- (3) The wheel did not cut to "Relief Angle", this it contacts the whole face of the work, causing the surface of processing rough and rugged. Also, the greater face of contact will cause burns and cracks.



- (4) The "Relief Angle" of the wheel is lower than the surface of the work, so that the work face becomes two sections, the upper section resembling that in (3) and the lower section in (1). Now it is necessary to enlarge the "Relief Angle" part so that it will higher than the face of the work.



- (5) If the spindle does not constitute a right angle with the work table surface, the side faces will turn out to be as shown:



## 17-6 RIGHT ANGLE GRINDING

### (1) Tools

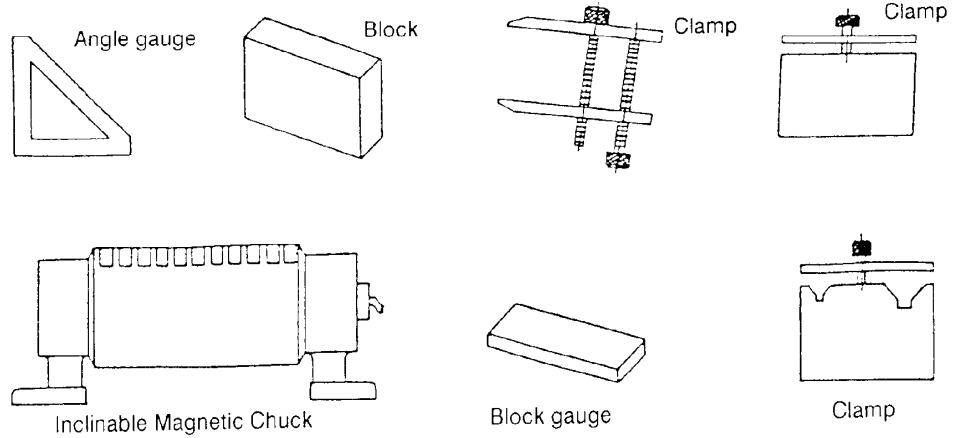

(2) Use of the jigs and tools: take the grinding of the block of six faces A, B, C, D, E, F. For example:

a. Under 200mm:

\* Grinding of the first basic face, or the surface grinding of A and B.



\* Grinding of C and D.

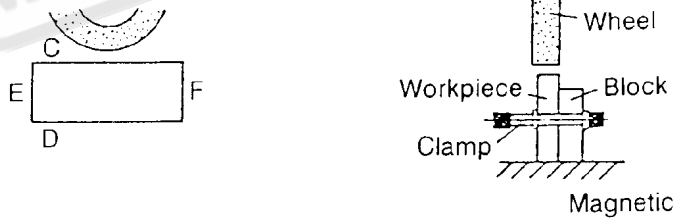

\* Grinding of E and F.

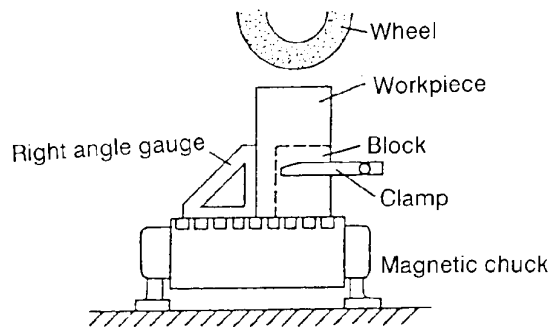

b. Over 200mm:

- \* Grinding of first basic face or A,
- \* Grinding of C and D: turn the inclinable magnetic chuck into 90°.

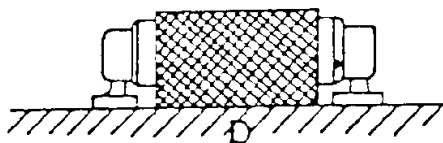

- \* Grinding of E and F.

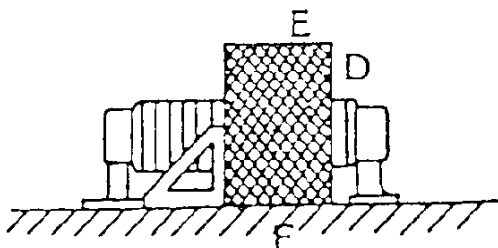

- (3) Precaution: The grinding of right angle depends on the patience and clever mindedness of the operator for its precision. For instance, Whether the burrs after grinding is done well, whether the tools are kept clean, whether the work table are kept clean the accuracy of the angle gauge, etc, all will have a direct influence over the precision of the product.

MACHINERYHOUSE

## C. ELECTRIC DIAGRAM AND PARTS LIST

### CONTENTS

1. FOR 1545/2045M .....	P. C-1
2. FOR 1545/2045/2550H.....	P. C-2
3. FOR 1545/2045/2550/3060AH(R) .....	P. C-3
4. FOR D2550/D3060/D4080AH(R).....	P. C-4
5. FOR DL2550/DL3060/DL4080AH(R).....	P. C-5

#### D TYPE:

1. Table longitudinal travel by sensor & solenoid valve.
2. Continuous lubrication.

#### DL TYPE:

1. Table longitudinal travel by sensor & solenoid valve.
2. Auto. crossing stroke adjustment by control panel switch.
3. Back water splash shield.
4. Continuous lubrication.

MACHINERYHOUSE

FOR 1545M/2045M

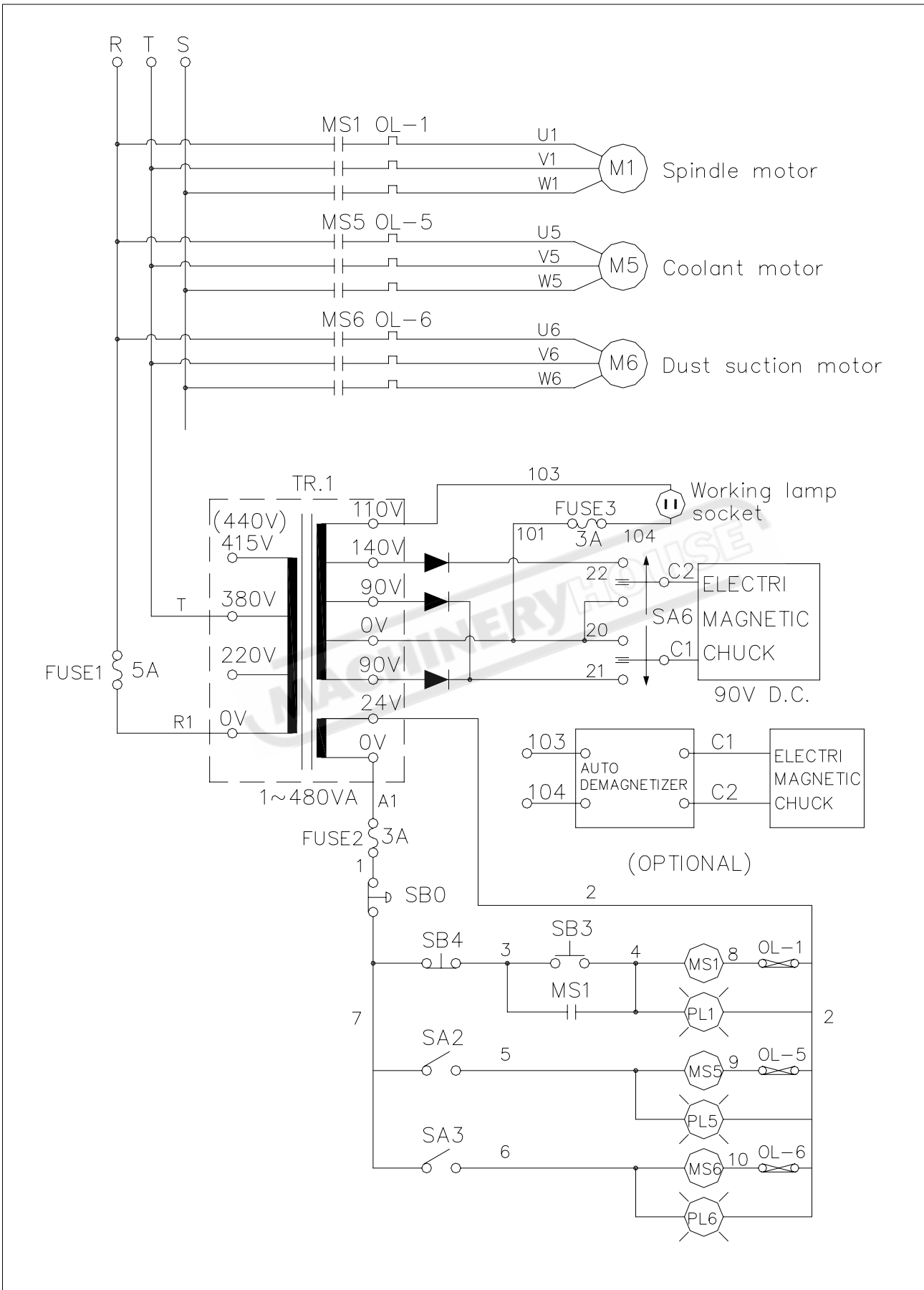

# FOR 1545H/2045H/2550H

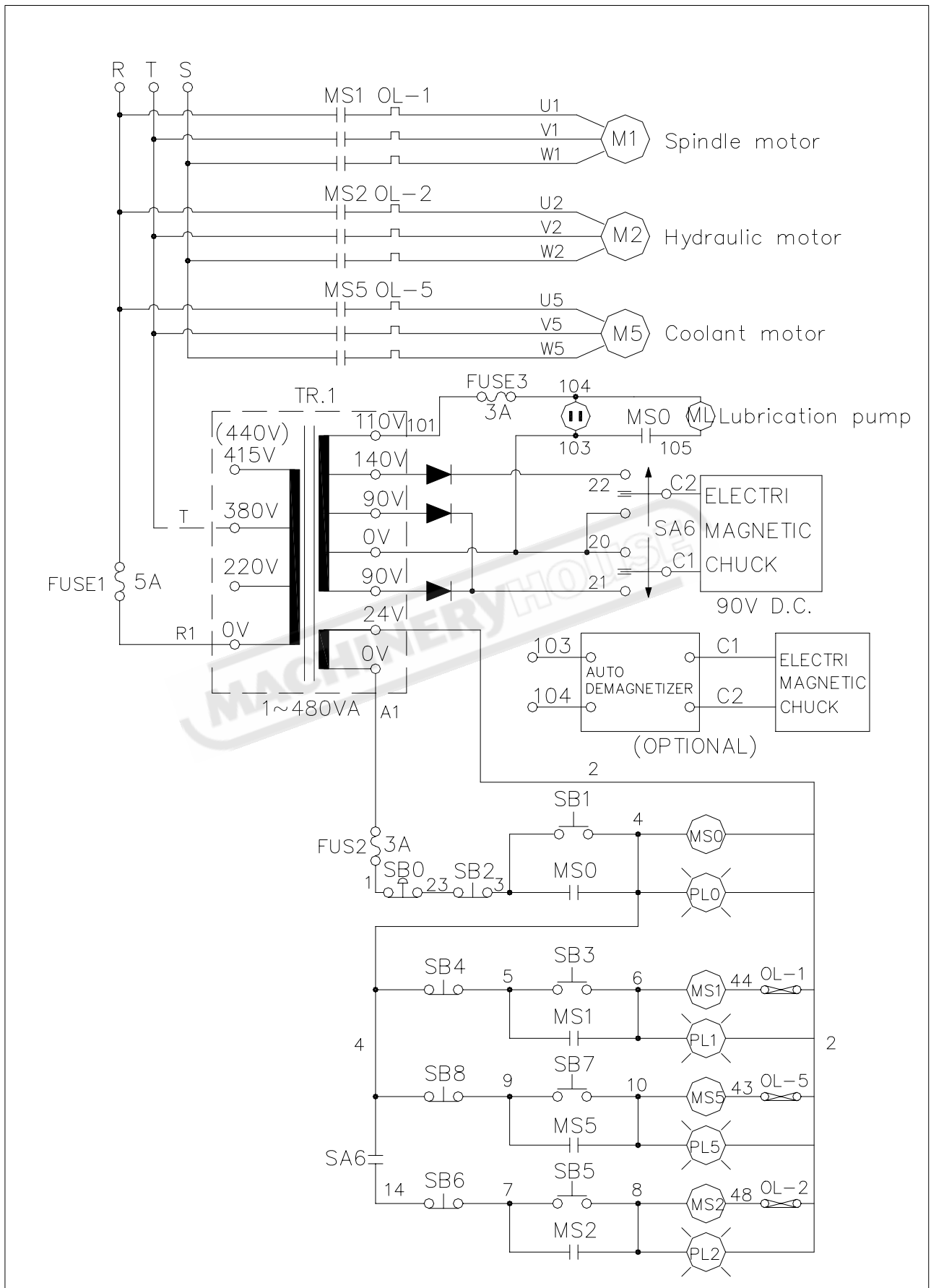

# FOR 1545AH(R)/2045AH(R)/2550AH(R)/3060AH(R)

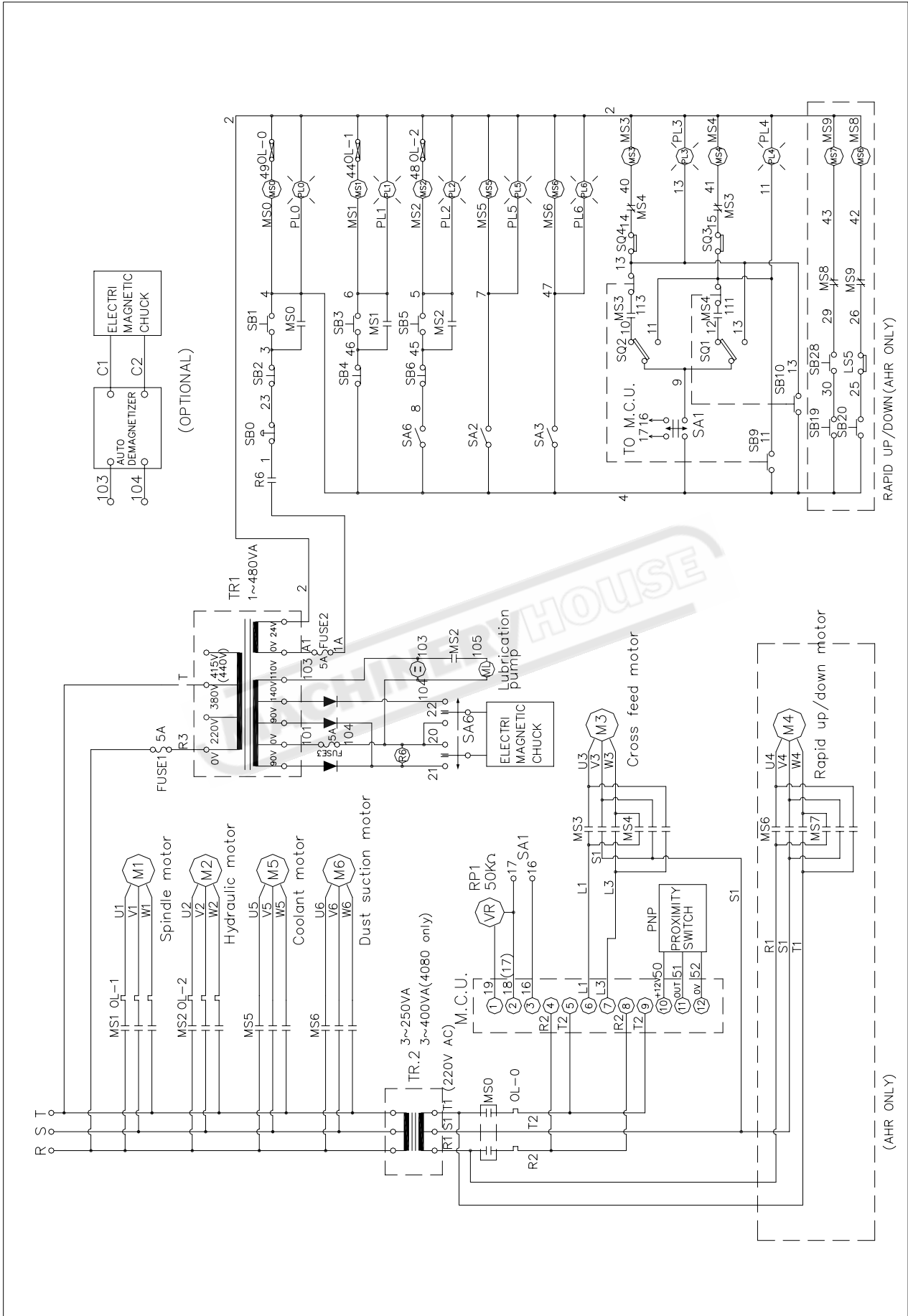

# FOR D2550AH(R)/D3060AH(R)/D4080AH(R)

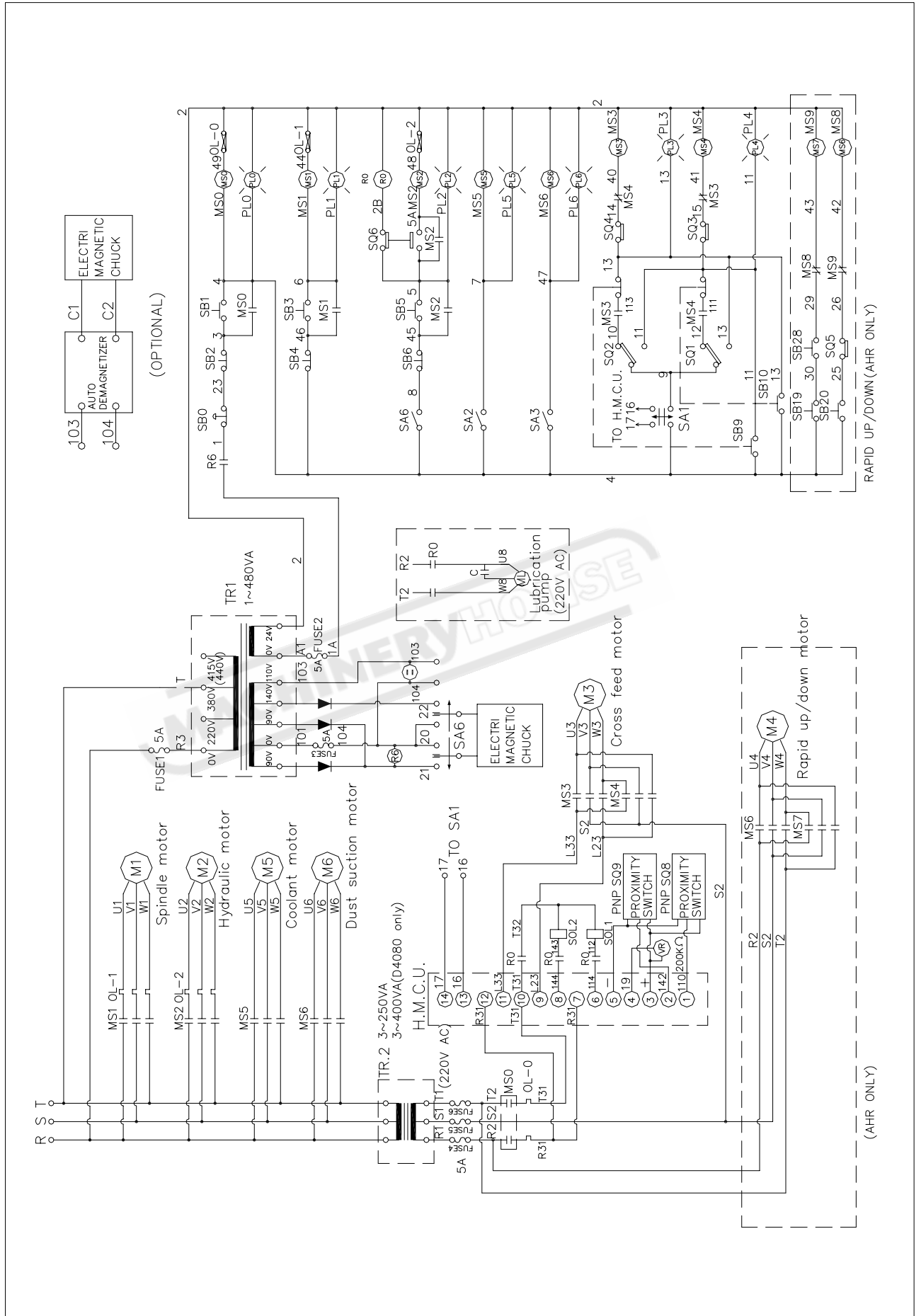



# FOR DL2550AH(R)/DL3060AH(R)/DL4080AH(R)

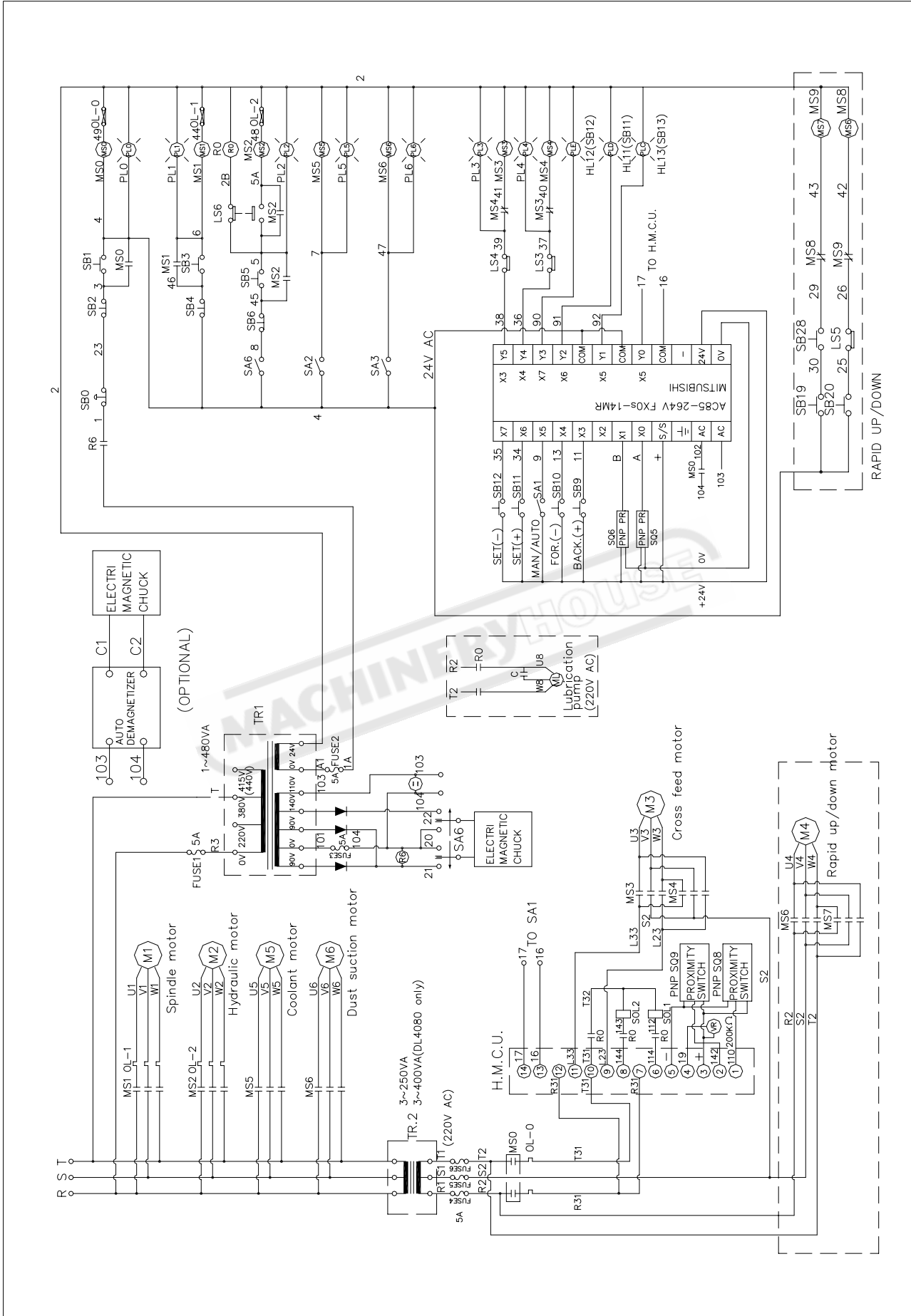

# D. COMPLETE DRAWING AND PARTS LIST

## CONTENTS

1. Base 、 Saddle 、 Table Ass'y (For 1545/2045M) .....	D-2
2. Base 、 Saddle 、 Table Ass'y (For 1545/2045H 、 AH) .....	D-3
3. Base 、 Saddle 、 Table Ass'y (For 2550H 、 AH /C3060AH/D4080AH) .	D-4
4. Column Ass'y.....	D-6
5. Spindle Ass'y .....	D-8
6. Vertical Ass'y .....	D-10
7. Cross Feed Ass'y (For 1545/2045M 、 H/2550H) .....	D-12
8. Cross Feed Ass'y.....	D-14
9. Longitudinal Hand Feed Ass'y (For 1545/2045M).....	D-16
10. Longitudinal Hand Feed Ass'y .....	D-18
11. Cylinder Ass'y .....	D-20
12. Valve Ass'y (For 1545/2045/2550/C3060H 、 AH) .....	D-22
13. Valve Ass'y (For D3060/D4080) .....	D-24
14. Dust Suction With Coolant System Ass'y (Optional Accessory) .....	D-26
15. Auto Down Feed Ass'y (Optional Accessory) .....	D-28
16. Micro feed for vertical Ass'y (Optional Accessory).....	D-30
17. Power rapid for vertical Ass'y (Optional Accessory) .....	D-32
18. Power rapid with Micro feed for vertical Ass'y (Optional Accessory) ....	D-34
19. M 、 H Micro cross feed Ass'y (Optional Accessory) .....	D-36
20. AH Micro cross feed Ass'y (Optional Accessory).....	D-38

## 1. Base 、 Saddle 、 Table Assembly Drawing (FOR 1545/2045M)

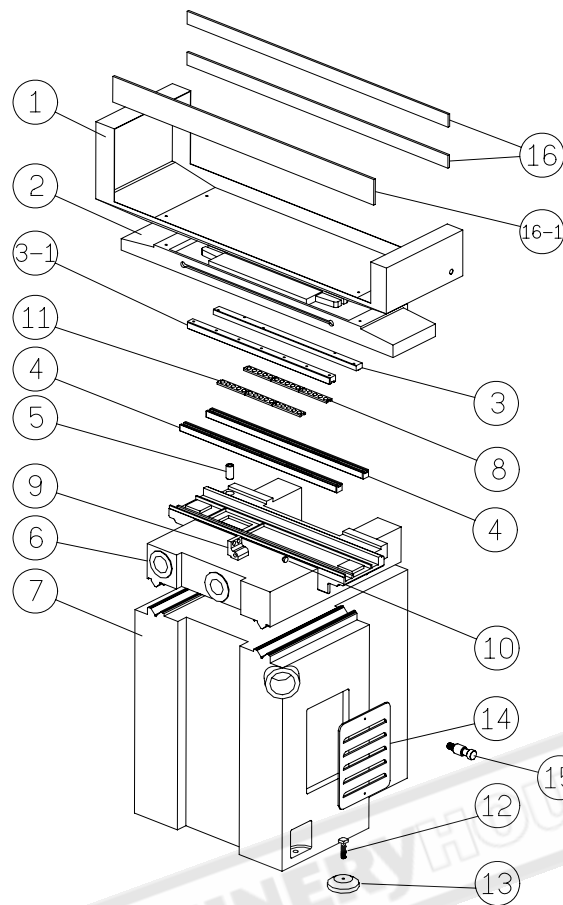

### ◎ Base 、 Saddle 、 Table Assembly Parts List (FOR 1545/2045M)

NO	Parts No.		Parts Name	Q
	1545M	2045M		
1	C15310	C20310	Table splash shield	1
2	C15103-M	C20103-M	Table	1
3	C15302	C15302	Slide way	1
3-1	C15303	C15303	Slide way	1
4	C15301	C15301	Slide way	2
5	251305	251305	Ball retainer stopper	4
6	C15102-M	C15102-M	Saddle	1
7	C15101	C15101	Base	1
8	B-5/8"	B-5/8"	Steel ball	44
9	251341	251341	Rubber cushion	1
10	251342	251342	Stopper	2
11	251304	251304	Steel ball retainer	9
12	910202	910202	Leveling screw	3
13	910204	910204	Pad	3
14	251112	251112	Side cover	2
15	910205	910205	Lifting blot	4
16	C15316	C15316	Table splash plate	2
16-1	C15315	C15315	Table splash plate	1

## 2. Base 、 Saddle 、 Table Assembly Drawing (FOR 1545/2045H 、 AH)

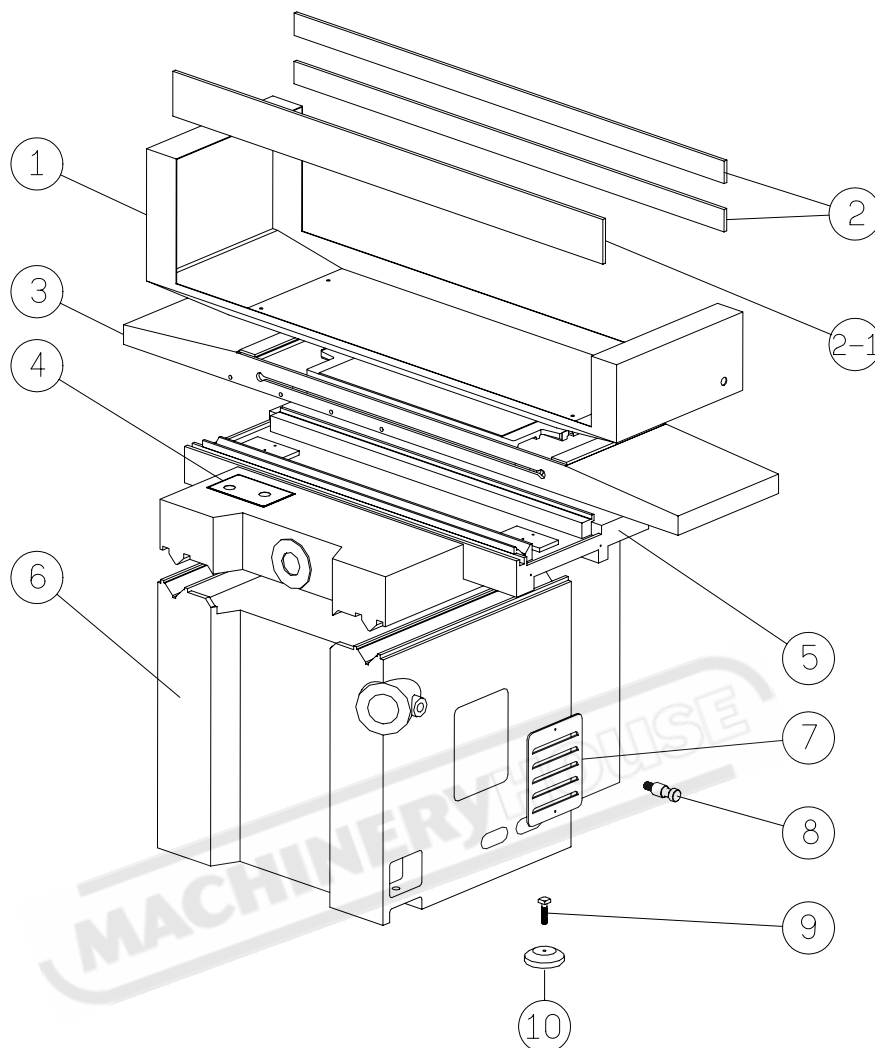

### ◎ Base 、 Saddle 、 Table Assembly Parts List (FOR 1545/2045H 、 AH)

NO	Parts No.		Parts Name	Q
	1545	2045		
1	C15314	C20314	Table splash shield	1
2	C15316	C15316	Table splash plate	2
2-1	C15315	C15315	Table splash plate	1
3	C15103-H	C15103-H	Table	1
4	PH-201	PH-201	Hydraulic indicator plate	1
5	C15102-H	C15102-H	Saddle	1
6	C15101	C15101	Base	1
7	251112	251112	Side cover	2
8	910205	910205	Lifting blot	4
9	910202	910202	Leveling screw	3
10	910204	910204	Pad	3

### 3. Base 、 Saddle 、 Table Assembly Drawing (FOR 2550H 、 AH/C3060AH/D4080AH)

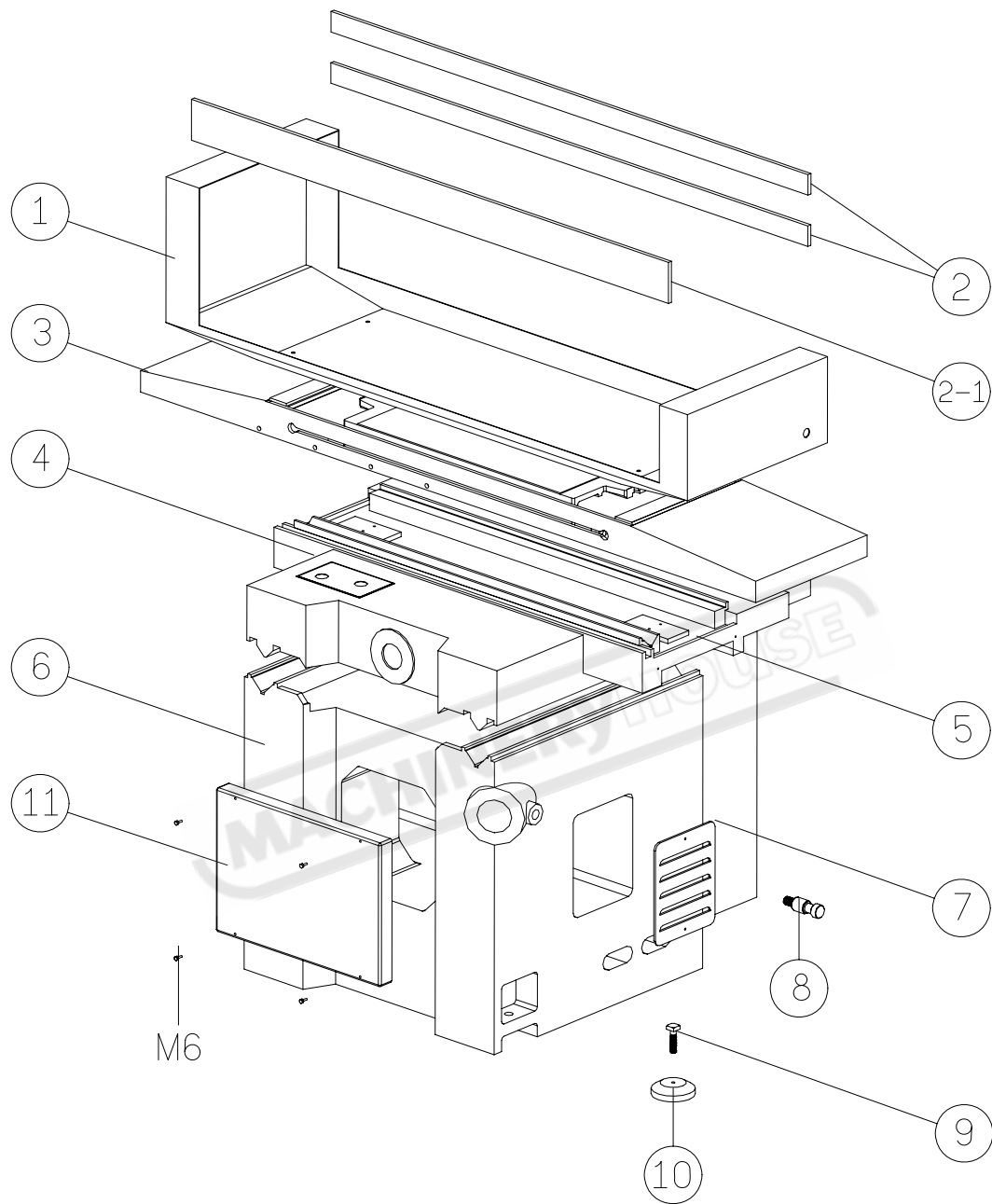

◎ Base 、 Saddle 、 Table Assembly Parts List  
 (FOR 2550/C3060/D4080H 、 AH)

NO	Parts No.			Parts Name	Q
	2550	C3060	D4080		
1	C25314	C36314	D40314	Table splash shield	1
2	C25316	C36316	D40316	Table splash plate	2
2-1	C25315	C36315	D40315	Table splash plate	1
3	C25103	C36103	D40103	Table	1
4	PH-201	PH-201	PH-201	Hydraulic indicator plate	1
5	C25102	C36102	D40102	Saddle	1
6	C25101	C36101	D40101	Base	1
7	251112	251112	251112	Side cover	2
8	910205	910205	910205	Lifting blot	4
9	910202	910202	910202	Leveling screw	3
10	910204	910204	910204	Pad	3(5)
11	C36107	C36107	C36107	Machine front cover	1

MACHINERYHOUSE

#### 4. Column Assembly Drawing (FOR 1545/2045/2550/C3060/D4080)

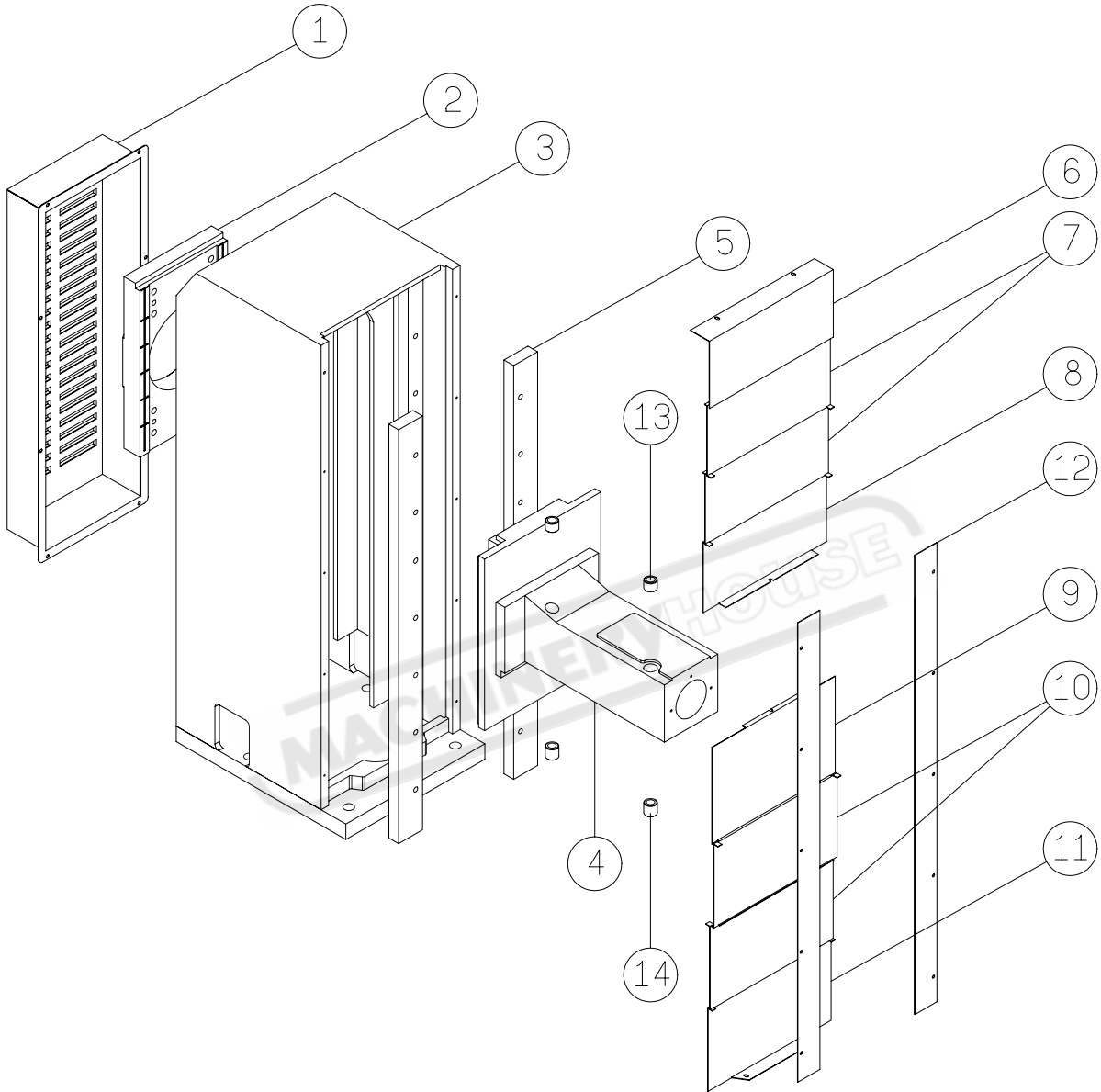

© Column Assembly Parts List  
(FOR 1545/2045/2550/C3060/D4080)

NO	Parts No.				Parts Name	Q
	1545 2045	2550	C3060	D4080		
1	C15419	301419	301419	D40419	Back cover of column	1
2	201412	C25412	301412	D40412	Motor bracket	1
3	C15104	C36104	C36104	D40104	Column	1
4	C15411 C20411	C25411	C36411	D40411	Spindle head	1
5	C15416PR	301416PR	301416PR	D40416PR	Vertical guide rail	2
6	C15425	C36425	C36425	D40421	Shield dust	1
7	C15426	C36426	C36426	D40422~23	Shield dust	2(3)
8	C15427	C36427	C36427	D40424	Shield dust	1
9	C15428	C36428	C36428	D40441	Shield dust	1
10	C15429	C36429	C36429	D40442~43	Shield dust	2(3)
11	C15430	C36430	C36430	D40444	Shield dust	1
12	C15424	C36424	C36424	D40415	Shield guide	2
13	C15414	251414	251414	251414	Under copper collar	2
14	C15413	251413	251413	251413	Below copper collar	2

MACHINERYHOUSE



### 5. Spindle Assembly Drawing (FOR 1545/2045/2550/3060/D4080)

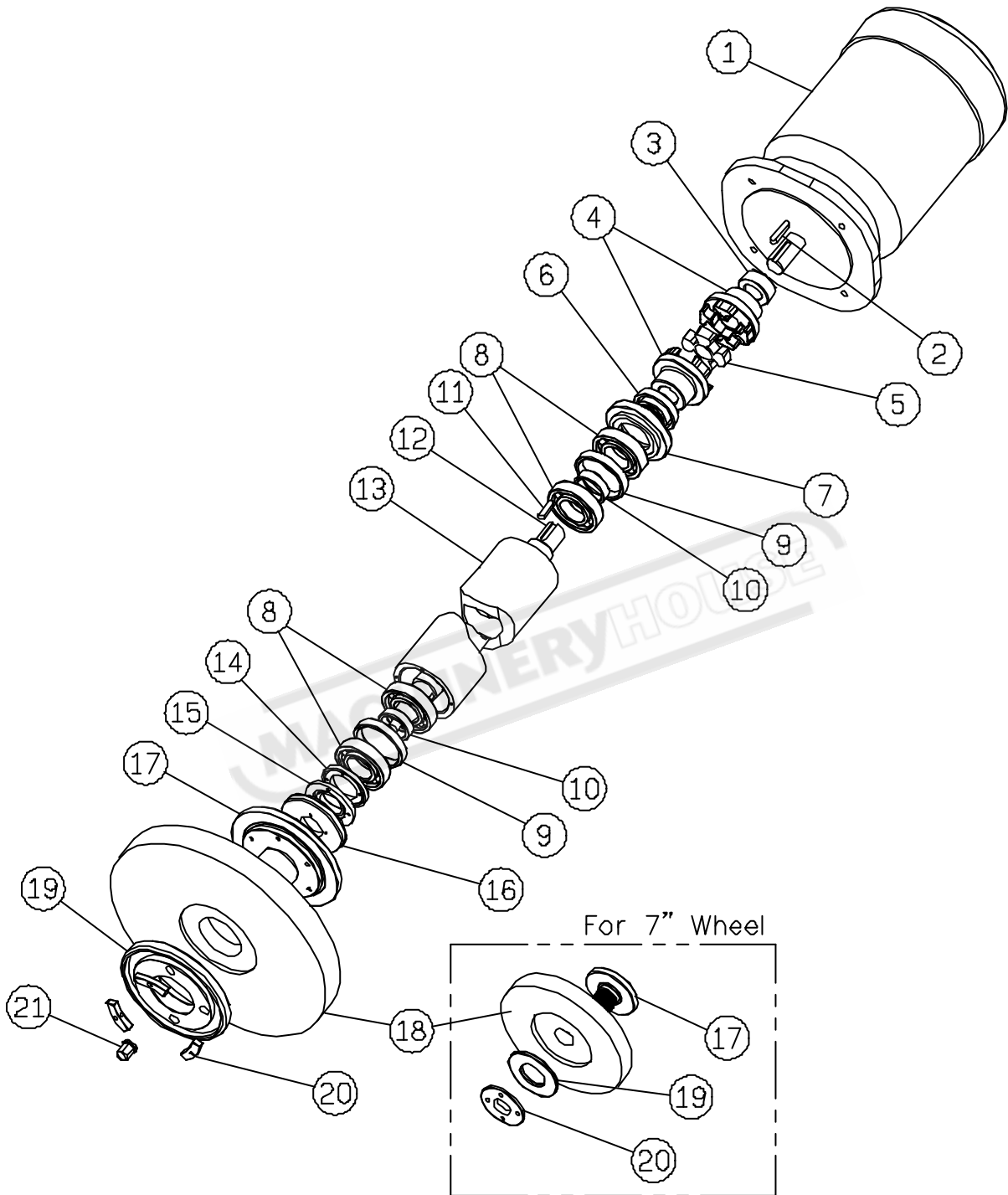

**Spindle Assembly Parts List**  
(FOR 1545/2045/2550/3060/D4080)

NO	Parts No.				Parts Name	Q
	1545 2045	2550	3060	D4080		
1	V-2HP-2P	V-2HP-2P	V-5HP-4P	V-5HP-4P	Spindle motor	1
2	K-P-8×7	K-P-8×7	K-P-8×7	K-P-8×7	Key	1
3	-	-	401502	401502	Washer	1
4	251511PR	C25511PR	301511PR	401511PR	Coupling	2
5	251513	251513	MT85-U	MT85-U	Rubber coupling	1
6	201510	C25510	C36510	D40510	Inner locking nut	1
7	201509	C25509	C36509	D40509	Outer locking nut	1
8	7206B	7206B	7208B	7209B	Angular contact bearing	4
9	201507	C25507	C36507	D40507	Spacer inner	2
10	201506	C25506	C36506	D40506	Spacer outer	2
11	K-P-8×7	K-P-8×7	K-P-8×7	K-P-8×7	Key	1
12	201502	C25502	C36502	D40502	Spindle shaft	1
13	201501	C25501	C36501	D40501	Spindle housing	1
14	201505	C25505	C36505	D40505	Outer locking nut	1
15	201504	C25504	C36504	D40504	Inner locking nut	1
16	201508	C25508	C36508	D40508	Spindle dust	1
17	910302A	910302A	910303A	910305	Wheel flange	1
18	WA46K	WA46K	WA46K	WA46K	Wheel	1
19	910302B	910302B	910303B	910304B	Wheel locking of flange	1
20	-	-	910303C	910303C	Flange balancing block	3
21	201503	C25503	C36503	D40503	Spindle nut	1

### 6. Vertical Assembly Drawing (FOR 1545/2045/2550/C3060/D4080)

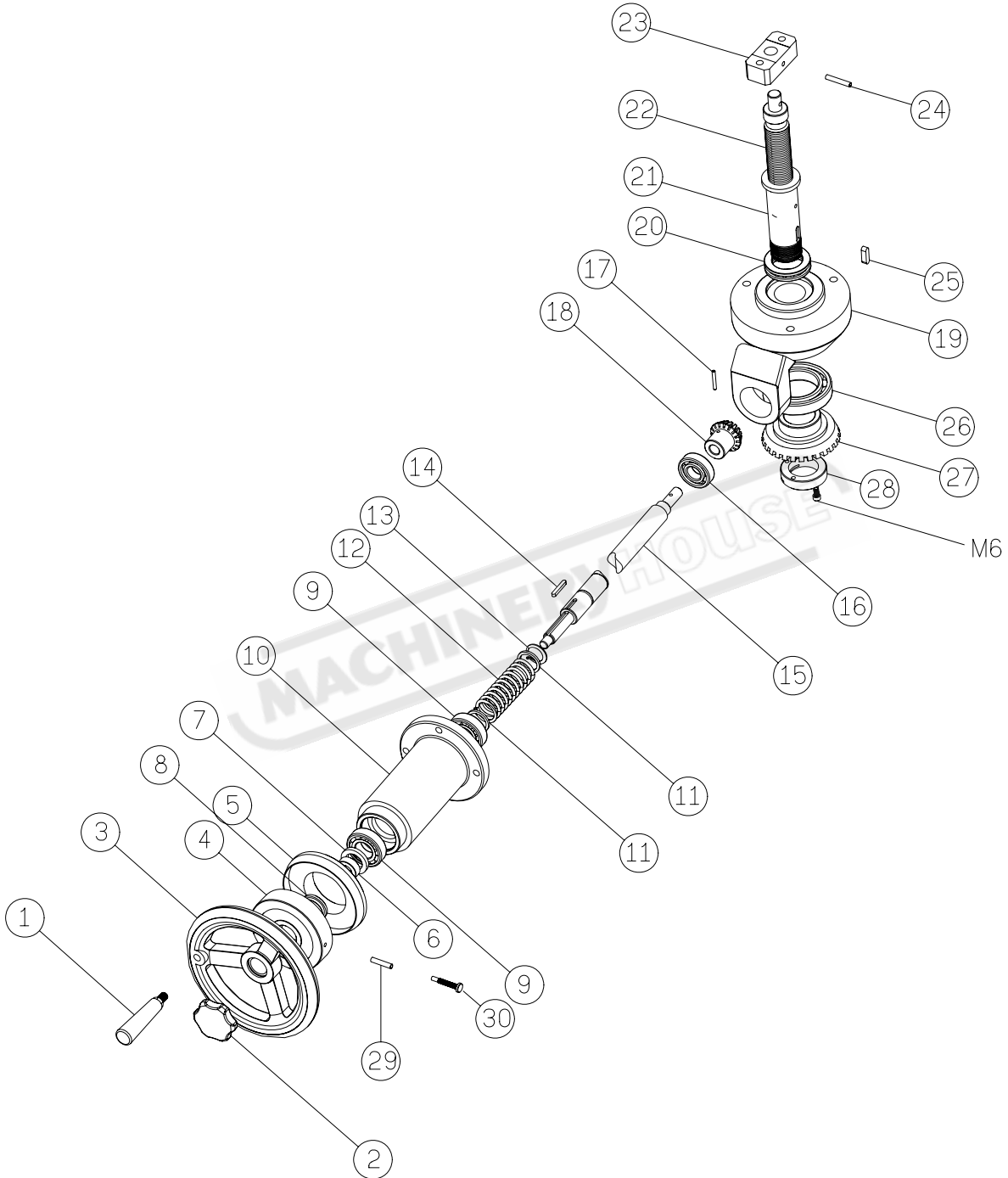

© Vertical Assembly Parts List  
(FOR 1545/2045/2550/C3060/D4080)

NO	Parts No.				Parts Name	Q
	1545 2045	2550	3060	D4080		
1	FN-80	FG-90	FG-90	FG-90	Handwheel grip	1
2	ENT-63- $\frac{1}{2}$ "	ENT-63- $\frac{1}{2}$ "	ENT-63- $\frac{1}{2}$ "	ENT-63- $\frac{1}{2}$ "	Handwheel nut	1
3	KRN-200	KSP-200	KSP-250	KSP-250	Handwheel	1
4	251401	251401	251401	401401	Graduation dial	4
5	251404	251404	251404	401404	Graduation dial holder	2
6	AN05	AN05	AN05	AN05	Check nut	2
7	AW05	AW05	AW05	AW05	Ratchet washer	1
8	251202	301202	301202	301202	Graduation dial bush	1
9	B-1205	B-1205	B-1205	B-1205	Ball bearing	1
10	201405	251405	251405	401405	Shaft hosing	1
11	251407	251407	251407	251407	Washing	2
12	251408	251408	251408	251408	Spring	1
13	S25	S25	S25	S25	C type snap ring	1
14	K-P-5×5×18L	K-P-5×5×18L	K-P-5×5×18L	K-P-5×5×18L	Key	1
15	C15406	C25406	301406	D40406	Shaft	1
16	B-6204	B-6204	B-6204	B-6204	Ball bearing	1
17					Spring pin	1
18	251409	251409	251409	251409	Small level gear	1
19	251434	251434	251434	251434	Bevel gear bracket	1
20	B-51108	B-51108	B-51108	B-51108	Thrust ball bearing	1
21	251436	251436	251436	251436	Leadscrew nut	1
22	251431	251431	251431	251431	Leadscrew	1
23	251433	251433	251433	251433	Connector	1
24					Spring pin	1
25	K-P-7×5×25L	K-P-7×5×25L	K-P-7×5×25L	K-P-7×5×25L	Key	1
26	B-6011	B-6011	B-6011	B-6011	Ball bearing	1
27	251435	251435	251435	251435	Level gear	1
28	251436	251436	251436	251436	Check nut	1
29	251403	251403	251403	251403	Pin	1
30	251205	251205	251205	251205	Set screw	1
31	M6×P1×12L	M6×P1×12L	M6×P1×12L	M6×P1×12L	Fixed screw	1

7. Cross Feed Assembly drawing  
(FOR 1545/2045M、H/2550H)

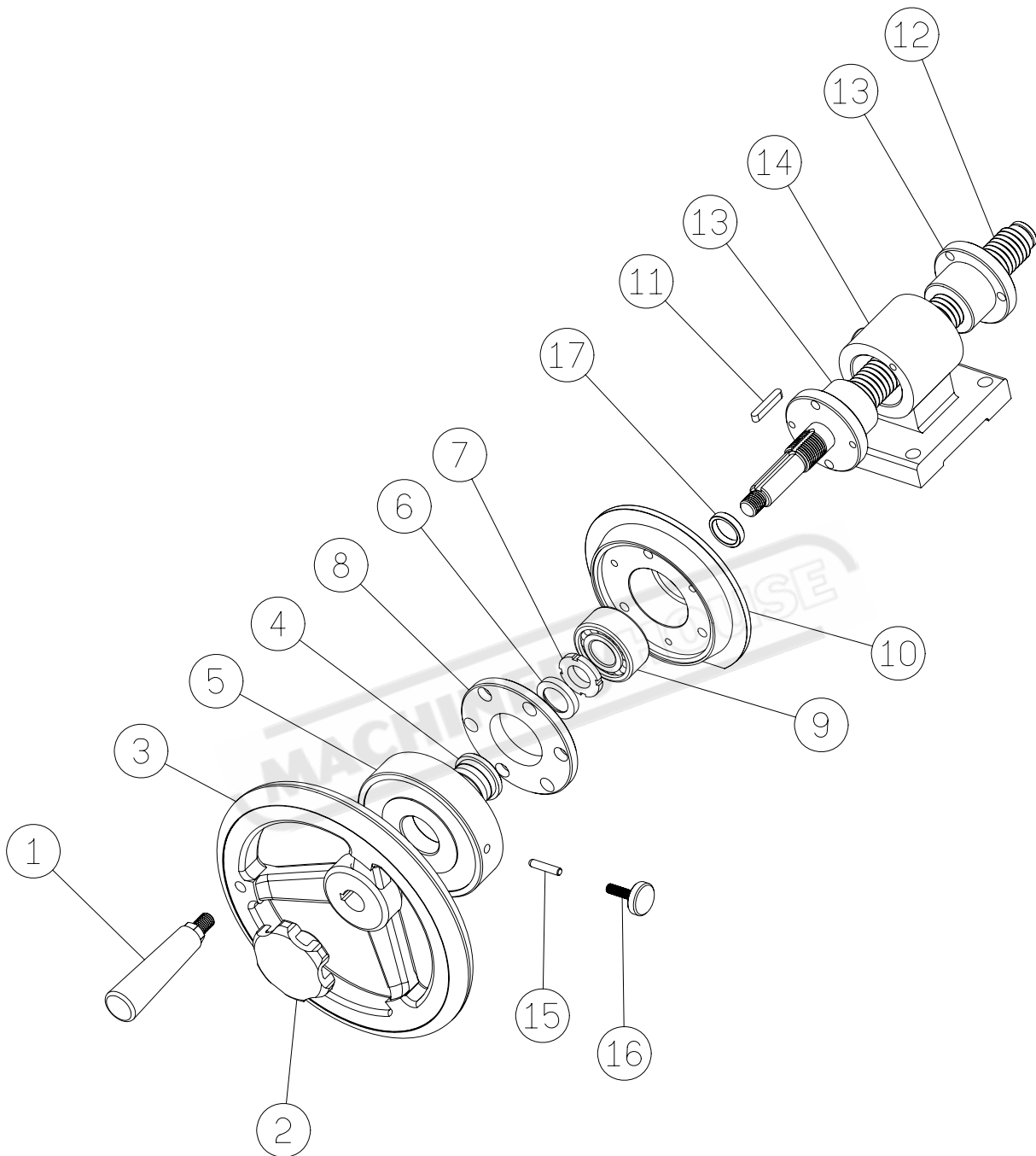

©Cross Feed Assembly Parts List  
(FOR 1545/2045M、H/2550H)

NO	Parts No.		Parts Name	Q
	1545/2045	2550		
1	FN-80	FG-90	Handwheel grip	1
2	ENT-63- $\frac{1}{2}$ "	ENT-63- $\frac{1}{2}$ "	Handwheel nut	1
3	KRN-160	KSP-200	Handwheel	1
4	251202	251202	Graduation dial bush	1
5	401201	251201	Graduation dial	1
6	AN05	AN05	Check nut	1
7	AW05	AW05	Ratchet washer	1
8	251204	251204	Graduation dial holding	1
9	B-3204	B-3204	Ball bearing	1
10	251206	251206	Bearing holding	1
11	K-P-5×5×30L	K-P-5×5×30L	Key	1
12	C15211	C25211	Cross feed leadscrew	1
13	C15212	C25212	Leadscrew nut	1
14	251222	251222	Screw base	1
15	251203	251203	Set pin	1
16	251205	251205	Set screw	1
17	251212	251212	Washer	1

MACHINERYHOUSE

### 8. Cross Feed Assembly Drawing (FOR 1545/2045/2550/C3060/D4080AH)

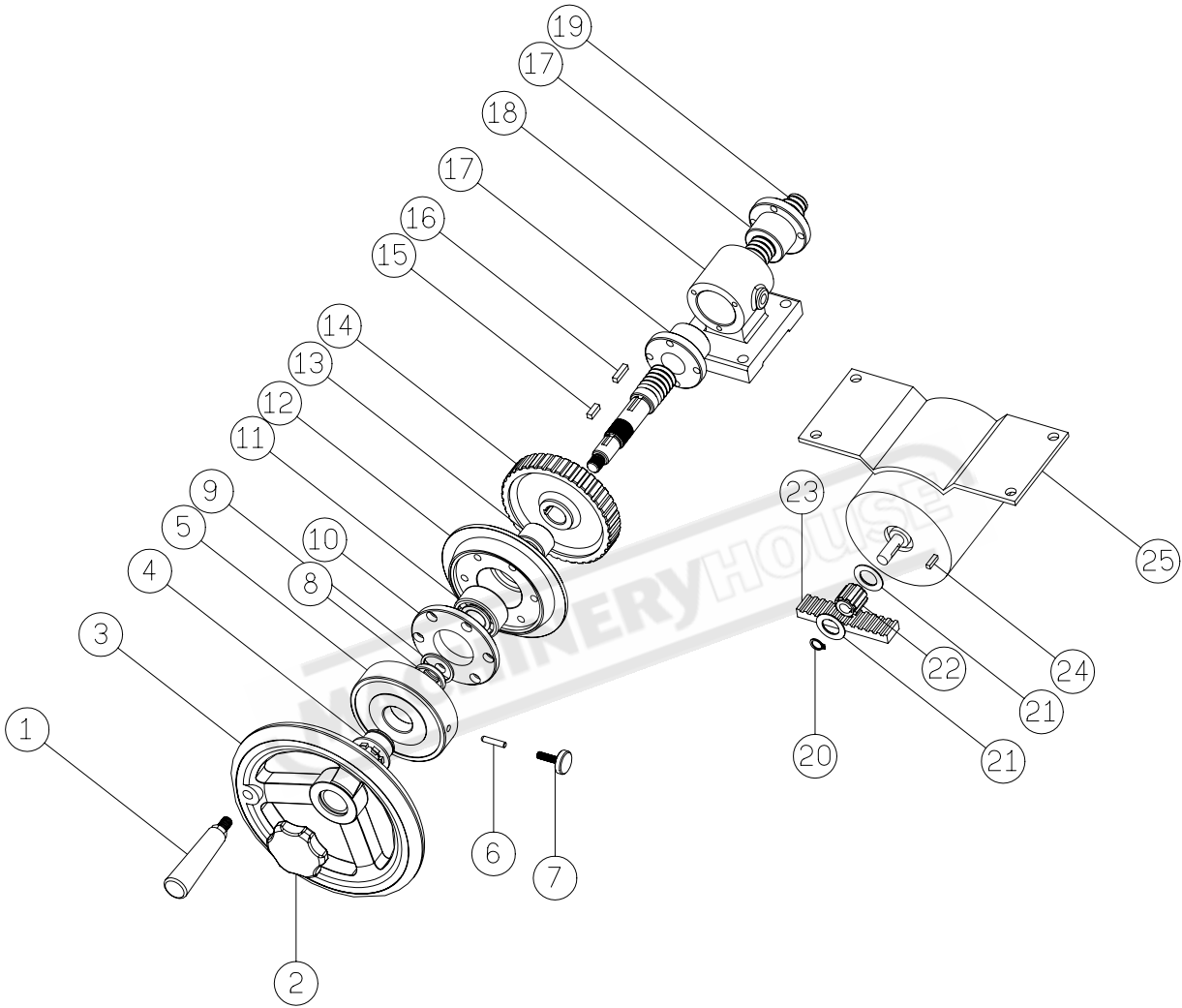

© Cross Feed Assembly Parts List  
(FOR 1545/2045/2550/C3060/D4080AH)

NO	Parts No.				Parts Name	Q
	1545 2045	2550	C3060	D4080		
1	FN-80	FG-90	FG-90	FG-90	Handwheel grip	1
2	ENT-63- $\frac{1}{2}$ "	ENT-63- $\frac{1}{2}$ "	ENT-63- $\frac{1}{2}$ "	ENT-63- $\frac{1}{2}$ "	Handwheel nut	1
3	KRNT-200	KSPT-200	KSPT-200	KSPT-200	Handwheel	1
4	251202	301202	301202	301202	Graduation dial bush	1
5	401201	401201	401201	401201	Graduation dial	1
6	251203	251203	251203	251203	Pin	1
7	251205	251205	251205	251205	Set screw	1
8	AN05	AN05	AN05	AN05	Check nut	1
9	AW05	AW05	AW05	AW05	Ratchet washer	1
10	251206	251206	251206	251206	Bearing holding	1
11	B-5204	B-5204	B-5204	B-5204	Ball bearing	1
12	251204	251204	251204	251204	Graduation dial holding	1
13	251231	251231	251231	251231	Washing	1
14	201232	251232	251232	251232	Timing belt pulley	1
15	K-P-5×5×15L	K-P-5×5×15L	K-P-5×5×15L	K-P-5×5×15L	Key	1
16	K-P-5×5×30L	K-P-5×5×30L	K-P-5×5×30L	K-P-5×5×30L	Key	1
17	C15212	251212	251212	251212	Leadscrew nut	1
18	251222	251222	251222	D40222	Screw base	1
19	C15211	C25211	C36211	D40211	Leadscrew Ballscrew (D4080 only)	1
20	SP11	SP11	SP11	SP11	Snap ring	1
21		251233	251233	251233	Washer	2
22	201234	251234	251234	251234	Timing belt pulley	1
23	T-150L50	T-187L75	T-187L75	T-187L75	Timing belt	1
24	K-P-4×4×10L	K-P-4×4×10L	K-P-4×4×10L	K-P-4×4×10L	Key	1
25	H-25W×4P	H- $\frac{1}{5}$ HP×6P	H- $\frac{1}{5}$ HP×6P	H- $\frac{1}{5}$ HP×6P	Cross feed motor	1



### 9. Longitudinal Hand Feed Assembly Drawing (FOR 1545/2045M)

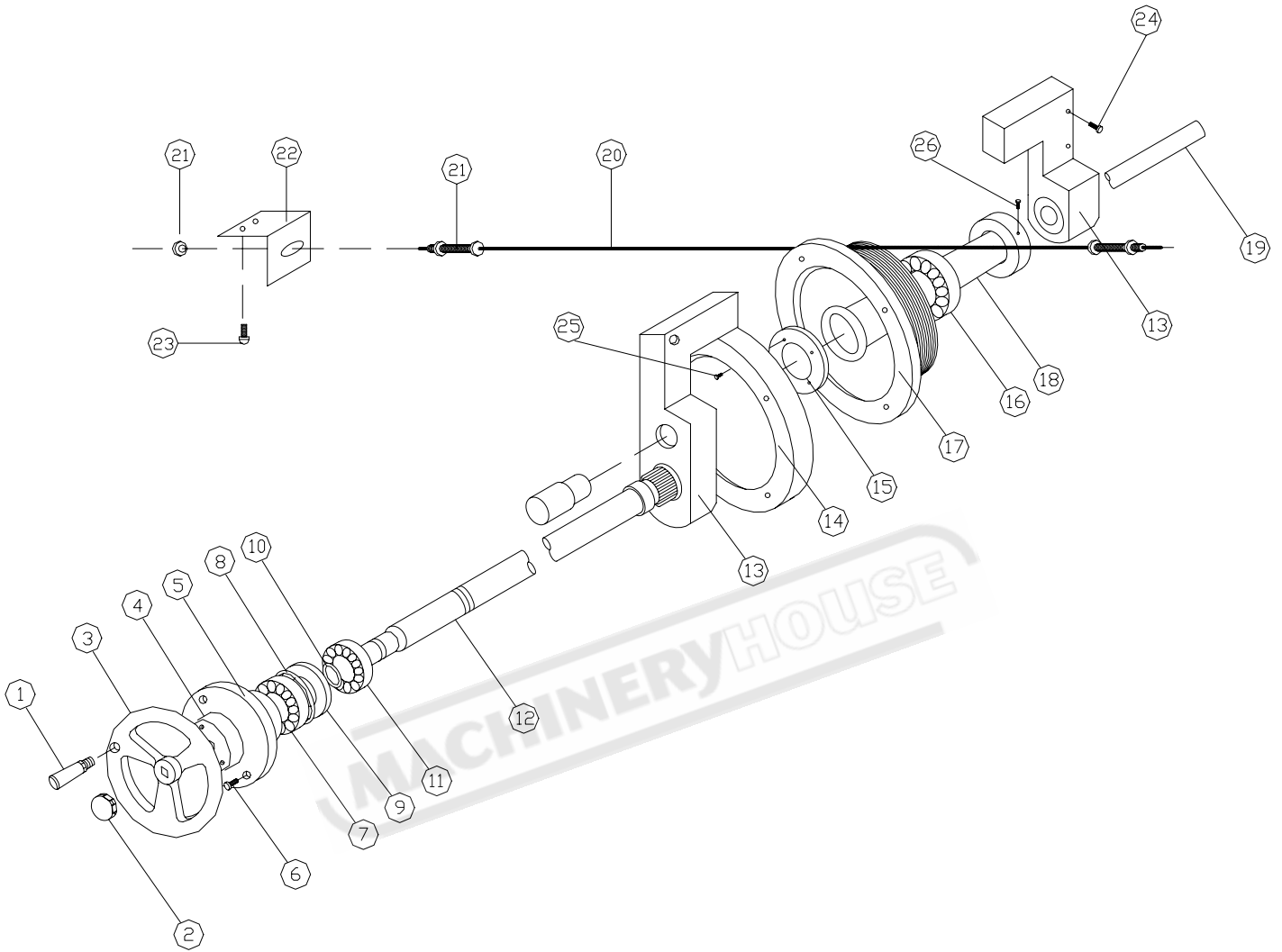

© Longitudinal Hand Feed Assembly Parts List  
(FOR 1545/2045M)

NO	Parts No.		Parts Name	Q
	1545	2045		
1	FN-80	FN-80	Handwheel grip	1
2	ENT-63- $\frac{1}{2}$ "	ENT-63- $\frac{1}{2}$ "	Handwheel nut	1
3	KRN-200	KRN-200	Handwheel	1
4	251323	251323	Nut	1
5	201321	201321	Bearing housing	1
6	F10476c	F10476c	Socket head cap screw	3
7	B-6204ZZ	B-6204ZZ	Ball bearing	1
8	SR47	SR47	Snap ring	1
9	251324	251324	Spacer	1
10	SP020	SP020	Snap ring	2
11	B-6004Z	B-6004Z	Ball bearing	1
12	C15322	C15322	Pinion shaft	1
13	201325	201325	Frame drum	1
14	201326	201326	Internal gear	1
15	SP025	SP025	Snap ring	1
16	B-6005Z	B-6005Z	Ball bearing	2
17	201327	201327	Drum	1
18	251328	251328	Bushing	1
19	201329	201329	Shaft	1
20	C15330	C15330	Wire rope	1
21	HN004	HN004	Hexagonal	4
22	251331	251331	End plate	2
23	F10406c	F10406c	Socket head cap screw	4
24	F10506c	F10506c	Socket head cap screw	4
25	F10404c	F10404c	Socket head cap screw	4
26	F20504c	F20504c	Set screw	3

### 10. Longitudinal Hand Feed Assembly Drawing (FOR 1545/2045/2550/C3060/D4080H、AH)

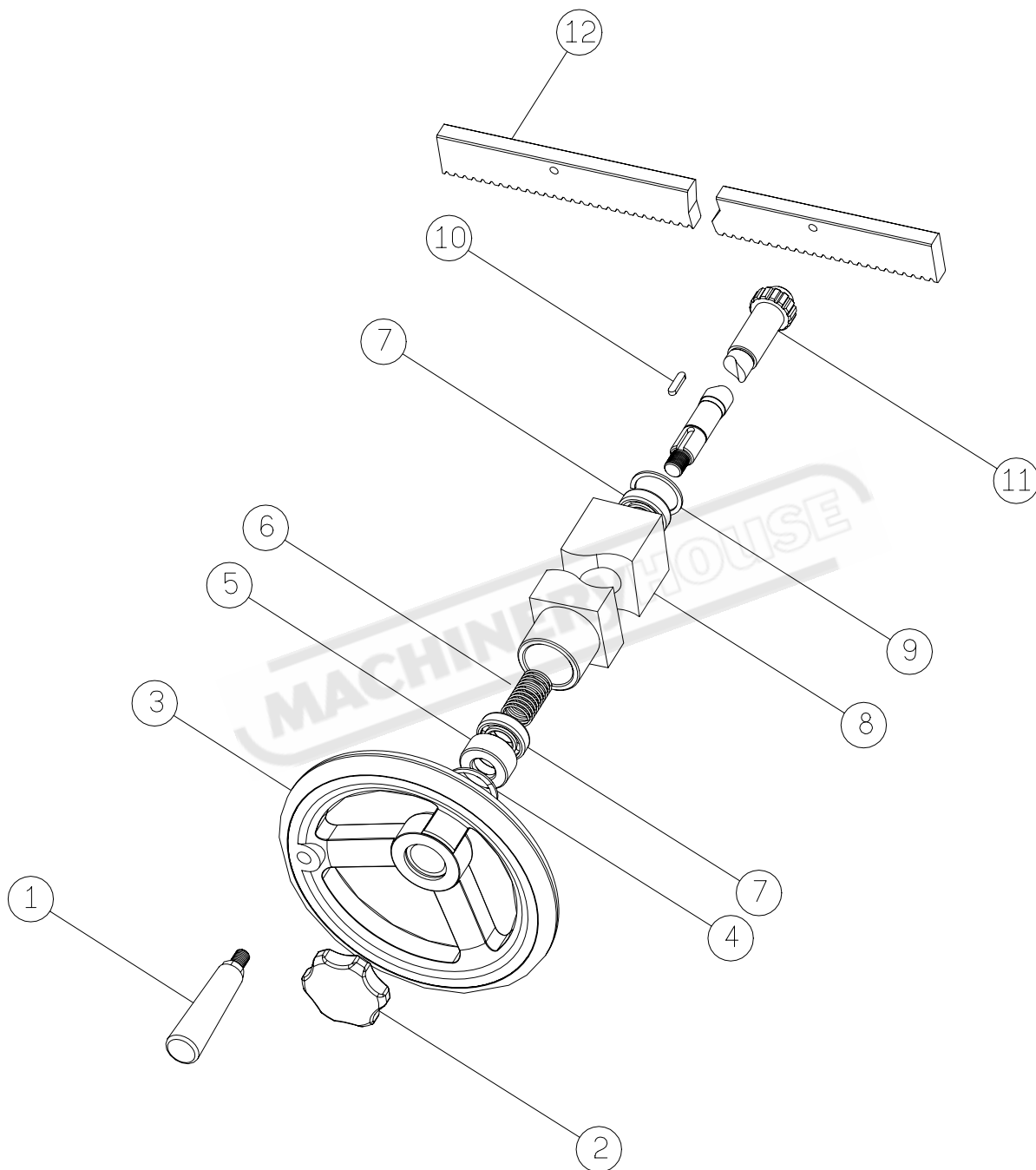

© Longitudinal Hand Feed Assembly Parts List  
(FOR 1545/2045/2550/3060/D4080H、AH)

NO	Part No.				Parts Name	Q
	1545 2045	2550	C3060	D4080		
1	FN-80	FG-90	FG-90	FG-90	Handwheel grip	1
2	ENT-63- $\frac{1}{2}$ "	ENT-63- $\frac{1}{2}$ "	ENT-63- $\frac{1}{2}$ "	ENT-63- $\frac{1}{2}$ "	Handwheel nut	1
3	KRN-200	KSP-200	KSP-200	KSP-250	Handwheel	1
4	SR17	SR17	SR17	SR17	Snap ring	1
5	251351	251351	251351	251351	Bush	1
6	251352	251352	251352	251352	Spring	1
7	B-6003Z	B-6003Z	B-6003Z	B-6003Z	Ball bearing	2
8	251353	251353	301353	D40353	Frame	1
9	SR35	SR35	SR35	SR35	Snap ring	1
10	K-P-5×5×20L	K-P-5×5×20L	K-P-5×5×20L	K-P-5×5×20L	Key	1
11	C25354	C25354	C36354	D40354	Pinion shaft	1
12	C15355	C25355	C36355	D40355	Gear rack	1

MACHINERYHOUSE

### 11. Cylinder Assembly Drawing (FOR 1545/2045/2550/C3060/D4080H、AH)

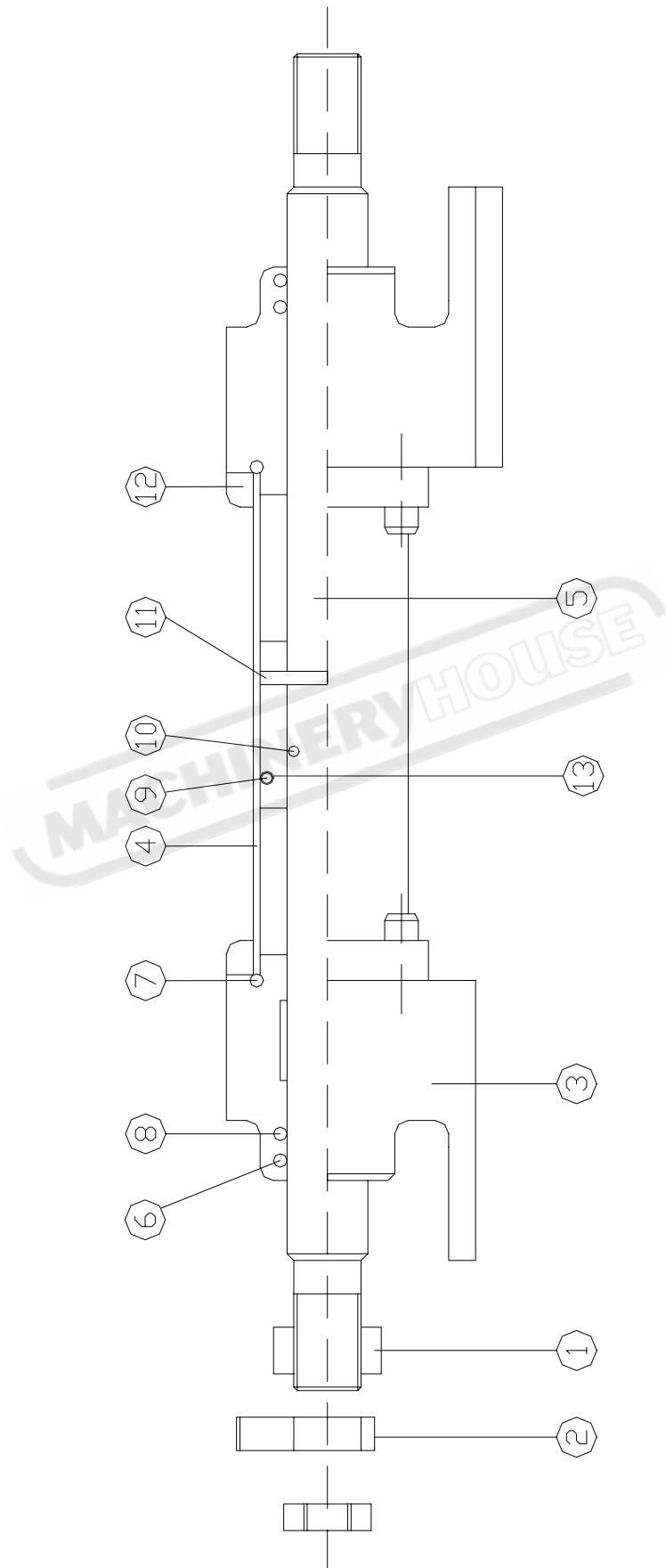

◎ Cylinder Assembly Parts List  
(FOR 1545/2045/2550/3060/D4080H、AH)

NO	Parts No.				Parts Name	Q
	1545 2045	2550	C3060	D4080		
1	251672	251672	251672	251672	Rubber cushion	2
2	251673	251673	251673	251673	End bracket	2
3	C15653	251653	251653	401653	Cylinder bracket	2
4	C15651	251651	C36651	401651	Cylinder	1
5	C15652	251652	C36652	401652	Piston rod	1
6	LBH12	LBH20	LBH20	PTU20	Dust seal ring	2
7	SM30	SM30	SM30	G35	Clamp ring	2
8	USH12	USH20	USH20	USH30	U-Parking	2
9	BUP21	BUP24	BUP24	USH30	Cylinder O-ring	2
10	P12	P24	P24	-	Diston O-ring	1
11	3w×1.5t×75L	TP24	TP24	-	Lock pin	1
12	C15658	251658	251658	D40658	Cylinder clamp	2
13	C15660	251660	251660	D40660	Piston	1

MACHINERYHOUSE

### 12. Valve Assembly Drawing (FOR 1545/2045/2550/C3060H、AH)

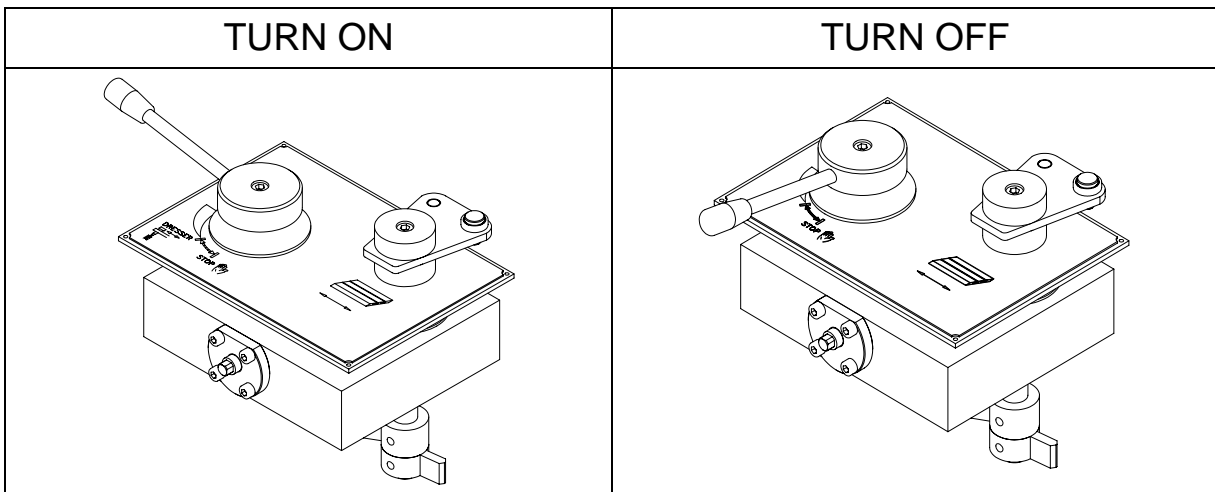
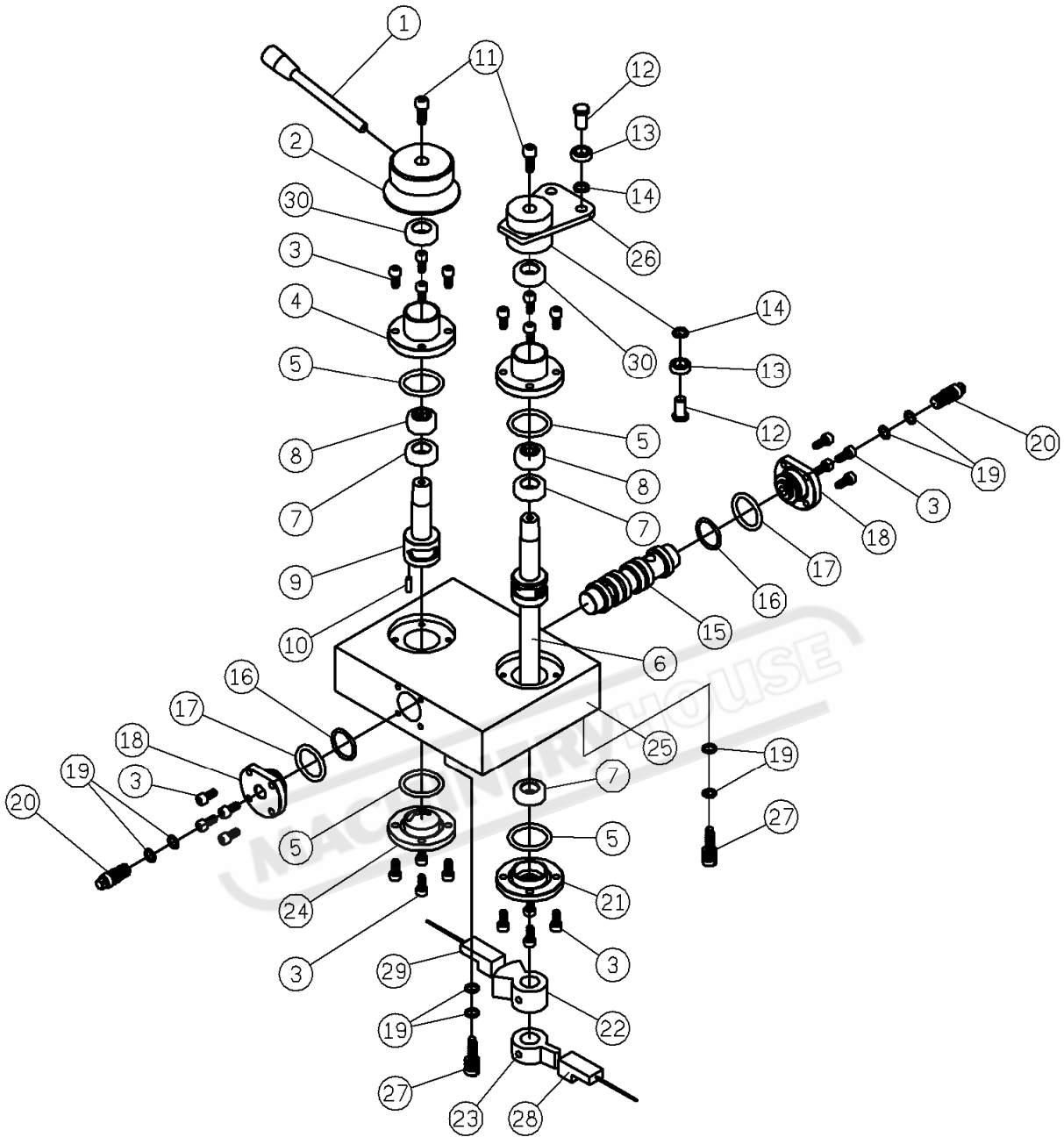

◎ Valve Assembly Parts List  
(FOR 1545/2045/2550/C3060H、AH)

NO	Parts No.	Parts Name	Q
1	251645	Flow control lever	1
2	251644	Flow control knob	1
3	M5	Set screw	24
4	251605	Upper cover	2
5	P28	O-ring	4
6	251606	Direction control shaft	1
7	GRE15	U-parking	3
8	1516	Oil-bearing	2
9	251609	Flow control shaft	1
10	P-P-4×13L	Pin	1
11	M6	Set screw	2
12	251641A	Bearing spindle	2
13	B-6008	Ball bearing	2
14	251641B	Washer	2
15	251637	Spool	1
16	P22	O-ring	2
17	P25	O-ring	2
18	251603	Side cover	2
19	P8	O-ring	8
20	251616	Adjusting screw	2
21	251608	Bottom cover	1
22	DF25408	Cam for auto down	1
23	251257	Cam for cross feed	1
24	251610	Bottom cover	1
25	251601	Valve base	1
26	251641	Direction control arm	1
27	251516	Adjusting screw	2
28	TL-E5EP1-3	Proximity switch for cross feed(50,51,52)	1
29	TL-E5EP1-3	Proximity switch for vertical(53,54,55)	1
30	LBH15	Dust seal ring	2



### 13. Valve Assembly Drawing (FOR D3060AH)

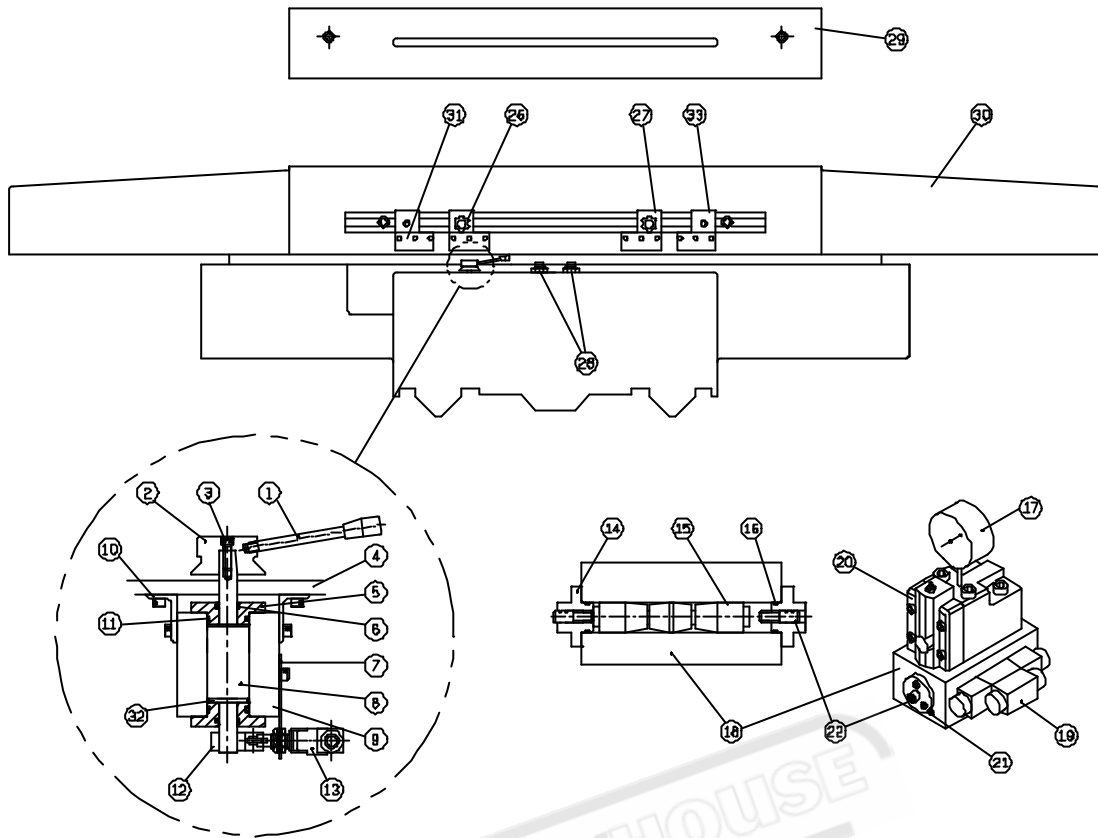

### (FOR D4080AH)

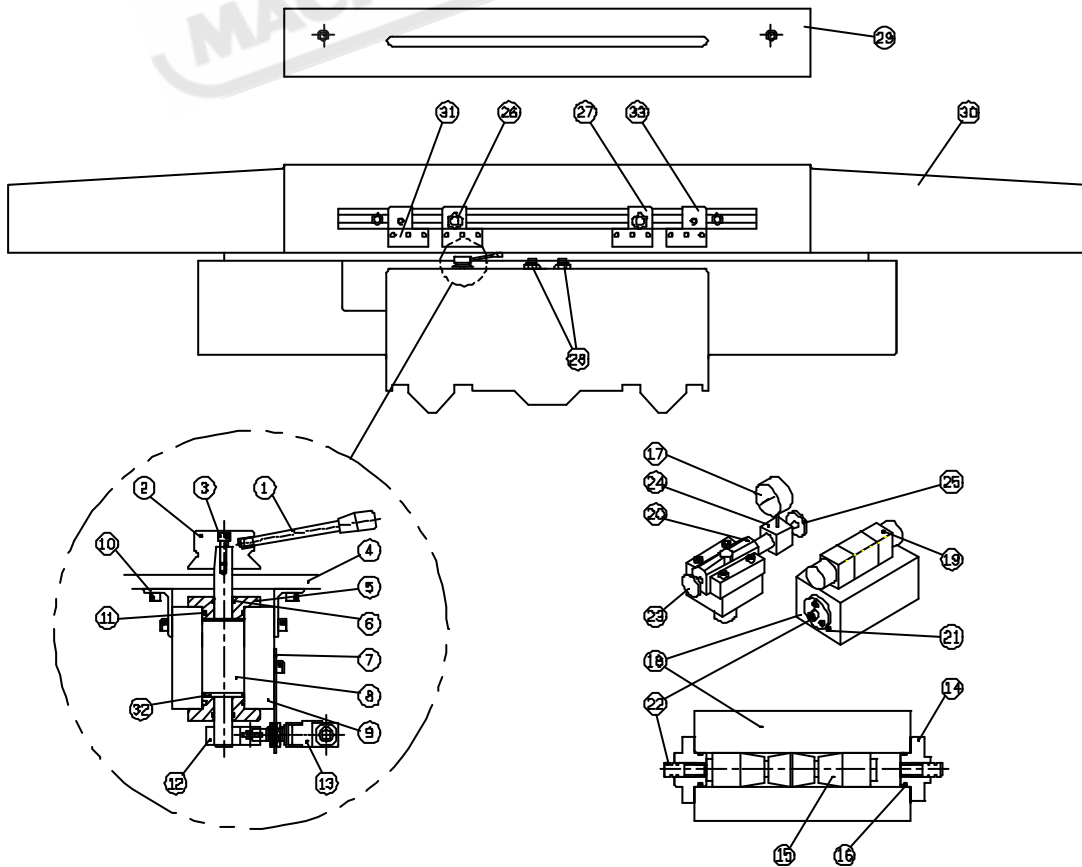

Valve Assembly Parts List  
(FOR D3060/D4080AH)

NO	Parts No.		Parts Name	Q
	D3060	D4080		
1	251645	251645	Flow control lever	1
2	251644	251644	Flow control knob	1
3	M6	M6	M6 fixed screw	1
4	D36102	D40102	Saddle	1
5	D36603	D36603	Side cover for flow valve	2
6	P15	P15	O-ring	2
7	D36634	D36634	Anchor plate for limits switch	1
8	D36602	D36602	Flow control shaft	1
9	D36601	D36601	Flow control valve	1
10	D36631	D36631	Anchor plate for valve	2
11	G30	G30	O-ring	2
12	D36632	D36632	Cam for solenoid	1
13	MN5311	MN5311	Limits switch	1
14	506103	506103	Side cover for direction valve	1
15	D36612	D36612	Direction shaft	1
16	P22	P22	O-ring	2
17	H-G04-50	H-GA04-50	Oil pressure gauge	1
18	D36611	D36611	Direction valve	1
19	SWH-G02-C7-220V	SWH-G02-C7-220V	Solenoid valve	1
20	RF-G04	RF-G04	Relief valve	1
21			Shake adjust screw	1
22	506109	506109	Adjust screw for side cover	2
23	-		Pressure regulating	1
24	-	H-CK04-50	Pressure gauge valve	1
25	-		Pressure gauge knob	1
26	D36341	D40341	Adjusting screw	2
27	D40343	D40343	Sensing chip	2
28	TM-X1204F1	TM-X1204F1	Proximity sensor	2
29	D36340	D40340	Protection shield	1
30	C36103	D40103	Table	1
31	D36344	D40344	Adjusting block	4
32			Anti-loose ring	1
33			Limit trip dog	2

### 15. Dust Suction with Coolant System Drawing (Optional Accessory)

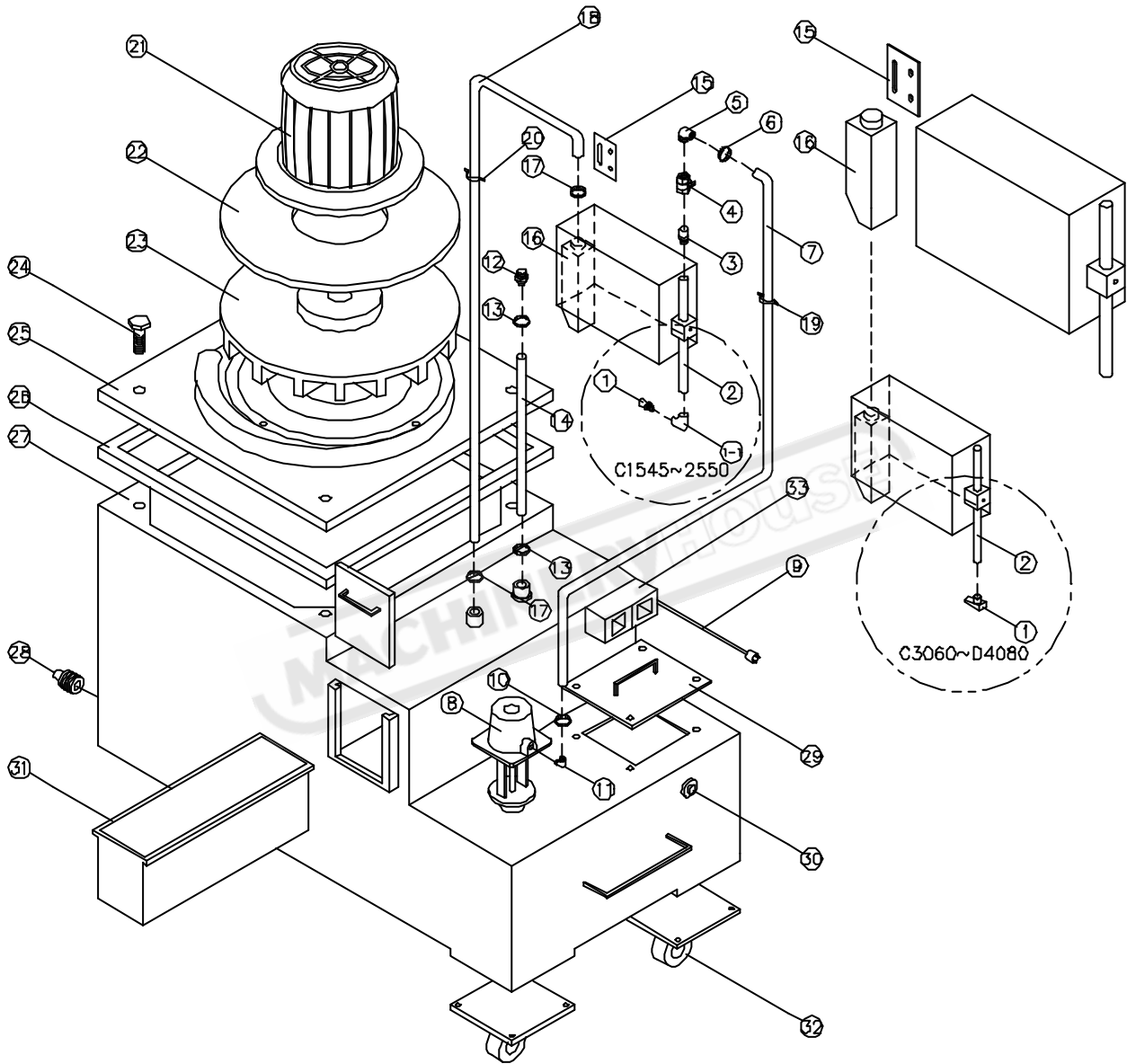

### ◎Dust Suction with Coolant System Assembly Parts List

NO	Parts No.		Parts Name	Q
	1545~ 2550	C3060~D4080		
1	C-PDK-06	C-PDK-06	Coolant nozzle	1
1-1	C-EL-06T×06TI	C-EL-06T×06TI	Nozzle elbow	1
2	910702	910702-1	Coolant pipe	1
3	910701	910701	Nipple pipe	1
4	C-BG-06	C-BG-06	Valve	1
5	C-EL-06TI×06TI	C-EL-06TI×06TI	Elbow	1
6	C-TC-08	C-TC-08	Clamp	1
7	C-NPH-08×3000	C-NPH-08×3000	Coolant hose	1
8	1/8HP-L180	1/8HP-L180	Pump	1
9			Cable & Socket	1
10	C-TC-08	C-TC-08	Clamp	1
11	C-EL-06T×06T	C-EL-06T×06T	Elbow	1
12			Snap-hose connector	1
13	C-TC-08	C-TC-08	Clamp	1
14	C-HS-08	C-HS-08	Snap hose	1
15			Dust collector plate	1
16	921422	921422	Dust collector	1
17	C-TC-08	C-TC-08	Clamp	2
18			Snap hose (Dust)	1
19			Clamp (Coolant hose)	1
20			Clamp (Dust hose)	1
21	MVB1322	MVB1322	Dust motor	1
22	921408	921408	Motor plate	1
23	921407	921407	Suction Fan	1
24	F3061004	F3061004	Screw	1
25	921404	921404	Upper cover	1
26	921405	921405	Cover packing	1
27	921401	921401	Tank	1
28			Plug	1
29	921404	921404	Coolant tank cover	1
30	GM00006	GM00006	Coolant indicator	1
31	921402	921402	Filter	1
32	JA00003	JA00003	Roller wheel	1
33	ES9600	ES9600	On-Off switch	1

### 15. Auto Down Feed Assembly Drawing (Optional Accessory) (FOR 1545/2045/2550/C3060/D4080)

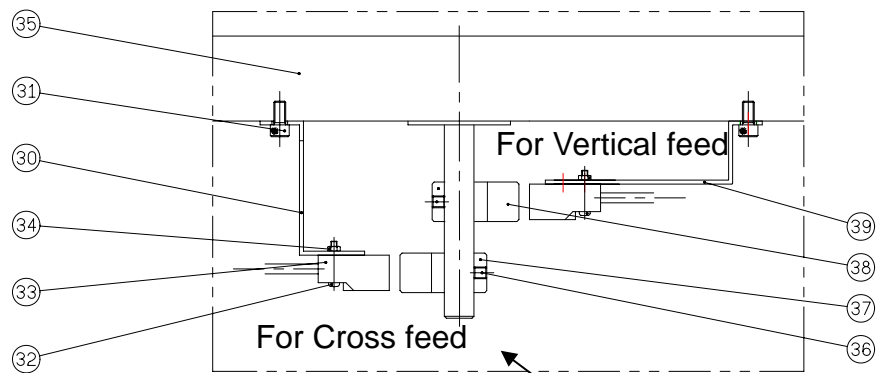
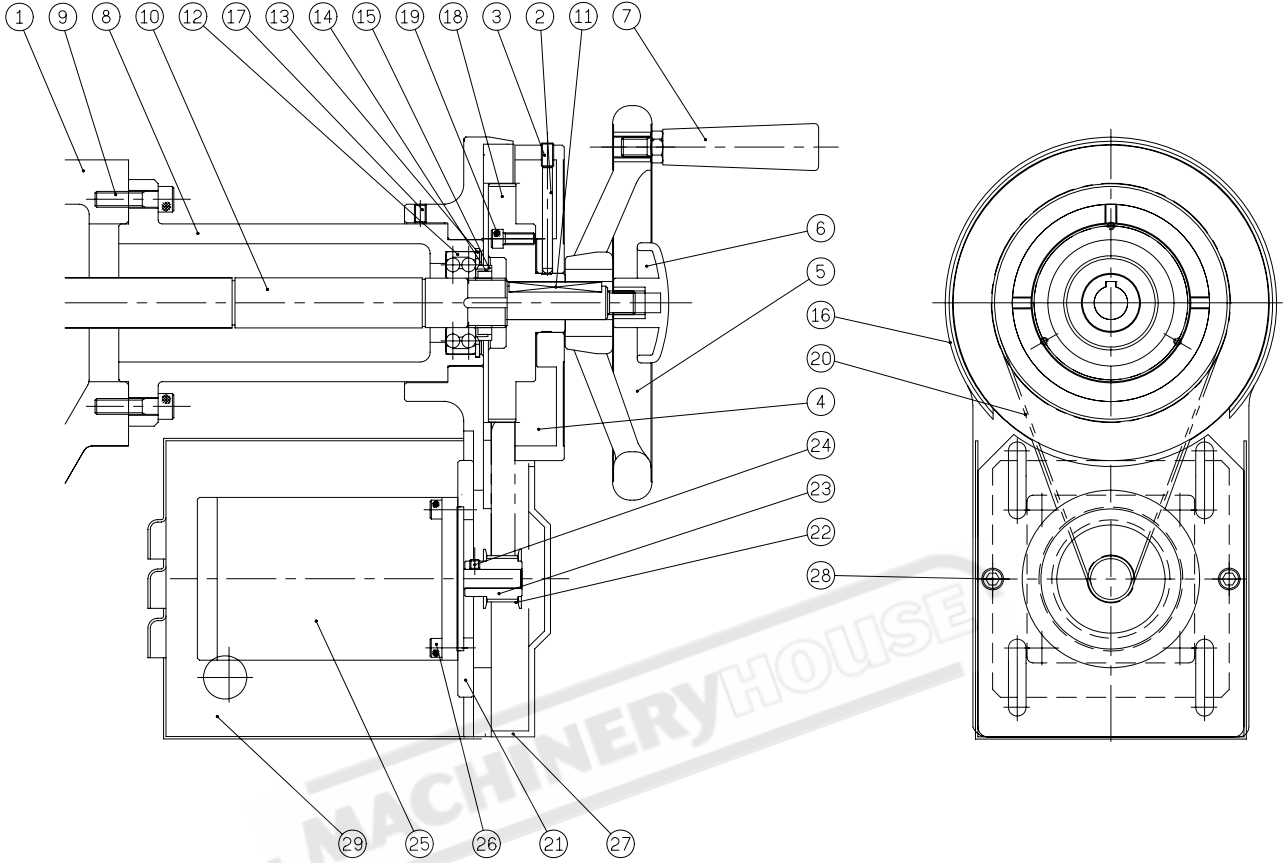

(1545/2045/2550/3060 only)

◎ Auto Down Feed Assembly Parts List  
(FOR 1545/2045/2550/C3060/D4080)

NO	Parts No.	Parts Name	Q
1	-	Base	1
2	251203	Set pin	1
3	251205	Set screw	1
4	DFC36412	Graduation dial	1
5	KRN-200(C1545/C2045) KSP-250	Handwheel	1
6	ENT-63-1/2"	Handwheel nut	1
7	FN-80(C1545/C2045) FG-90	Handwheel grip	1
8	251405	Shaft hosing	1
9	M8×P1.25×30L	Fixed screw	3
10	251406	Transmission shaft	1
11	5×5×50L	Key	1
12	B-1205	Ball bearing	1
13	RTW#55	C shape snap ring	1
14	AW05	Ratchet washer	1
15	AN05	Check nut	1
16	DFC36401	Graduation dial holder	1
17	M6×P1.0×8L	Fixed screw	2
18	DFC36403	Timing belt pulley	1
19	M6×P1.0×15L	Fixed screw	3
20	T-210XL37	Timing belt	1
21	DFC36404	Holding plate	1
22	251233	Pulley washer	2
23	DFC36405	Timing belt pulley	1
24	M5×P0.8×5L	Fixed screw	2
25	4H8618M0308	Stepping motor	1
26	M6×P1.0×15L	Fixed screw	1
27	DFC36406	Belt protection cover	1
28	M5×P1.0×15L	Fixed screw	3
29	DF25407	Stepping motor protection cover	1
30	DF40409	Proximity switch hosing	1
31	M6×P1.0×10L	Fixed screw	1
32	M3×P0.5×20L	Fixed screw	2
33	TL-E5PE1-3	Proximity switch	2
34	M3×P0.5	Fixed screw	2
35	251630PR	Hydraulic valve	1
36	M6×P1.0×6L	Fixed screw	2
37	251257	Cam for cross feed	1
38	DF25408	Cam for auto down	1
39	251256	Proximity switch hosing	1

### 16. Micro feed for vertical Assembly Drawing (Optional Accessory) (FOR 1545/2045/2550/C3060/D4080)

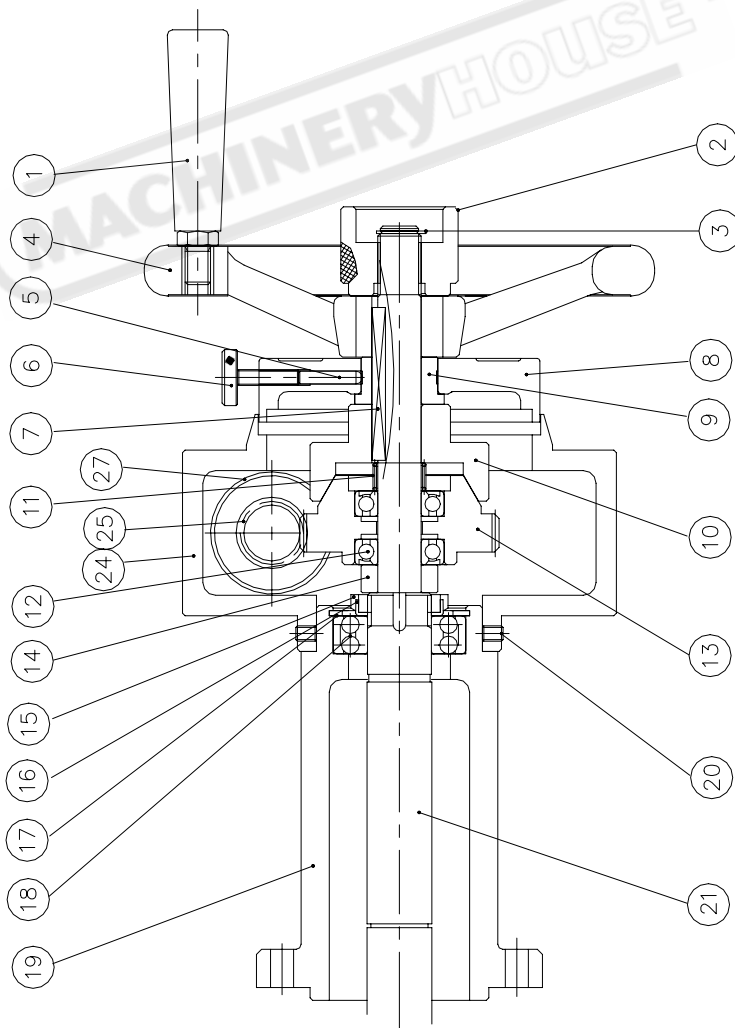
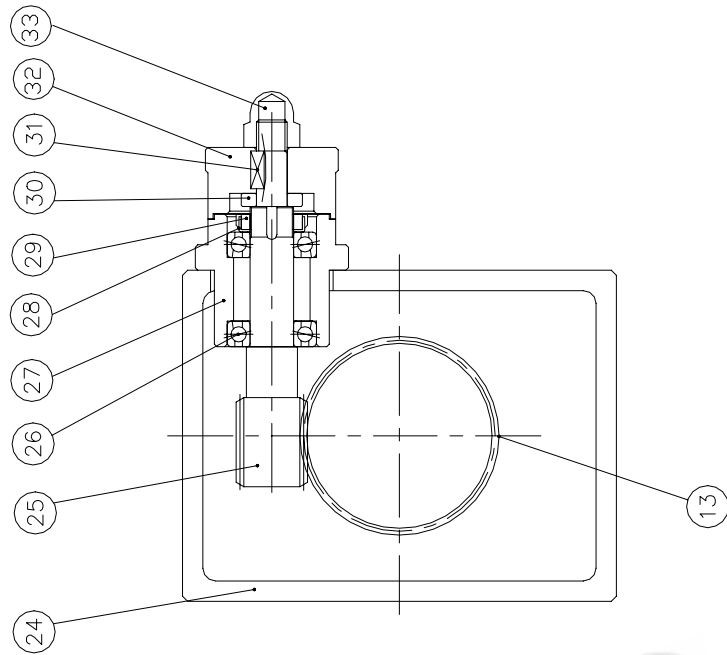

◎ Micro feed for vertical Assembly Parts List  
(FOR 1545/2045/2550/C3060/D4080)

NO	Parts No.	Parts Name	Q
1	FG-90	Handwheel grip	1
2	MF25405	Nut	1
3	STW#15	C-shaped snap ring	1
4	KSP-250	Handwheel	1
5	251403	Set pin	1
6	251205	Set screw	1
7	5×5×60L	Key	1
8	251401	Graduation dial	1
9	251202	Graduation dial bush	1
10	MF25404	Friction gear	1
11	251352	Spring	1
12	B-6003Z	Ball bearing	2
13	MF25403	Spiral gear	1
14	251410	Dial washer	1
15	AN05	Check nut	1
16	AW05	Ratchet washer	1
17	STW#55	C-shaped snap ring	1
18	B-1205	Ball bearing	1
19	MF20400	Transmission shaft base	1
20	M6×P1.0×6L	Fixed screw	4
21	MF25401	Transmission shaft	1
22	-	-	-
23	-	-	-
24	MF25402	Micro feed housing	1
25	MF25408	Micro feed worm	1
26	B-7003	Ball bearing	2
27	MF25407M	Worm bearing base	1
28	AW03	Ratchet washer	1
29	AN03	Chuck nut	1
30	MF25409	Set ring	1
31	5×5×15L	Key	1
32	MF25410M	Micro feed dial	1
33	M12×P1.75	Fixed nut	1



### 17. Power rapid for vertical Assembly Drawing (Optional Accessory) (FOR 1545/2045/2550/C3060/D4080)

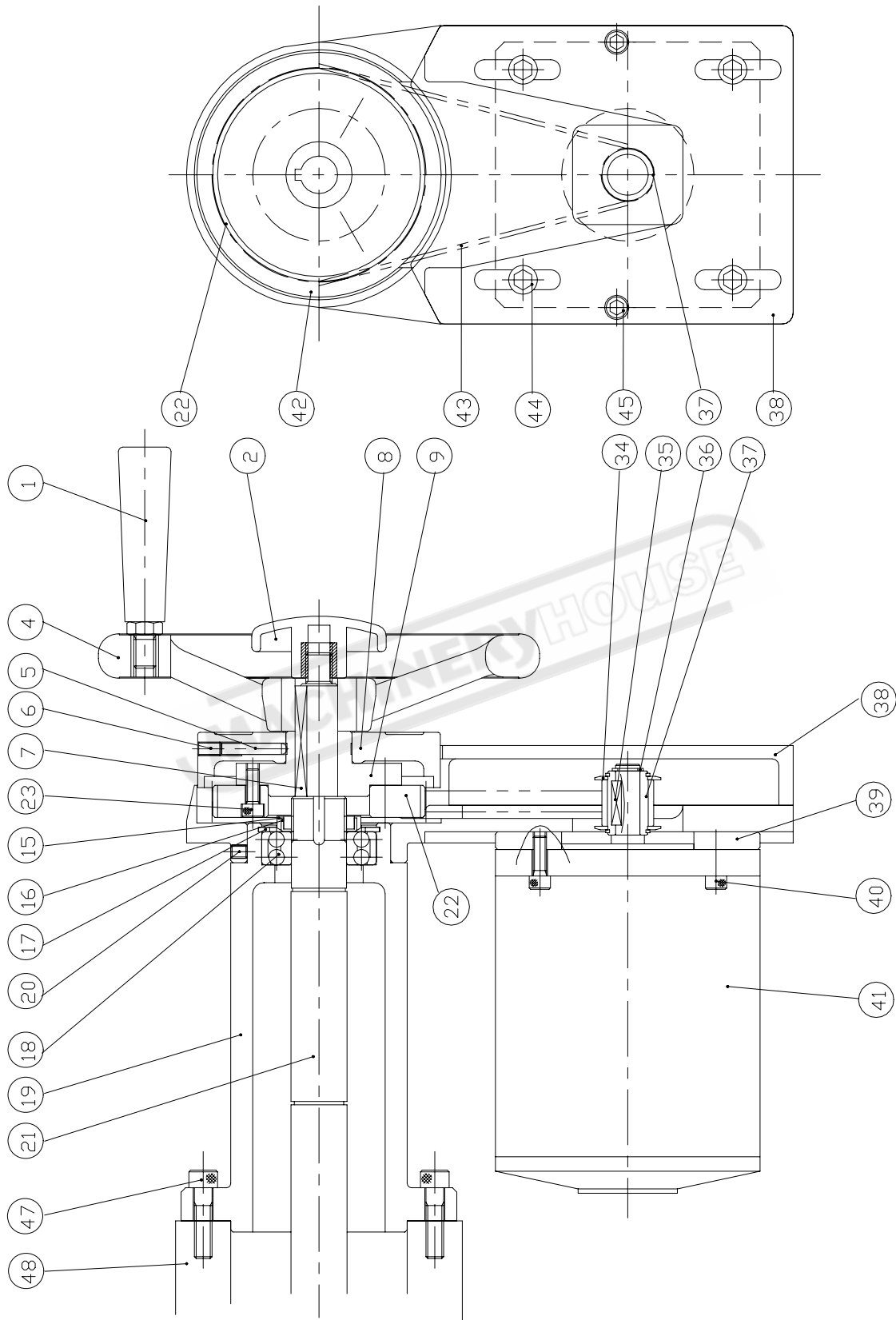

◎ Power rapid for vertical Assembly Parts List  
(FOR 1545/2045/2550/C3060/D4080)

NO	Parts No.	Parts Name	Q
1	FR-90	Handwheel grip	1
2	ENT-63-1/2"	Handwheel nut	1
3	-		-
4	KSP-250	handwheel	1
5	251403	Set pin	1
6	W1/4"-20×10L	Fixed screw	1
7	5×5×50L	Key	1
8	251401	Graduation dial	1
9	DF25402	Timing belt pulley bush	1
10	-		-
11	-		-
12	-		-
13	-		-
14	-		-
15	AN05	Check nut	1
16	AW05	Ratchet washer	1
17	STW#55	C-shaped snap ring	1
18	B-1205	Ball bearing	1
19	251405	Transmission shaft base	1
20	M6×P1.0×8L	Fixed screw	2
21	251406	Transmission shaft	1
22	DF25403	Timing belt pulley	1
23	M6×P1.0×15L	Fixed screw	3
24	-		-
25	-		-
26	-		-
27	-		-
28	-		-
29	-		-
30	-		-
31	-		-
32	-		-
33	-		-
34	251233	Timing belt pulley cover	1
35	4×4×20L	key	1
36	STW#11	C-shaped snap ring	1
37	251234	Timing belt pulley	1
38	DF25406	Belt protection cover	1
39	DF25404	Motor fixed plate	1
40	M6×P1.0×15L	Fixed screw	4
41	1/5HP×6P	AC motor	1
42	DF25401M	Indication dial base	1
43	T-187L037	Timing belt	1
44	M8×P1.25×20L	Fixed screw	4
45	M6×P1.0×15L	Fixed screw	2
46	-		-
47	M8×P1.25×30L	Fixed screw	3
48	C25101	Base	1

18. Power rapid with micro feed for vertical Assembly Drawing (Optional Accessory)  
(FOR 1545/2045/2550/C3060/D4080)

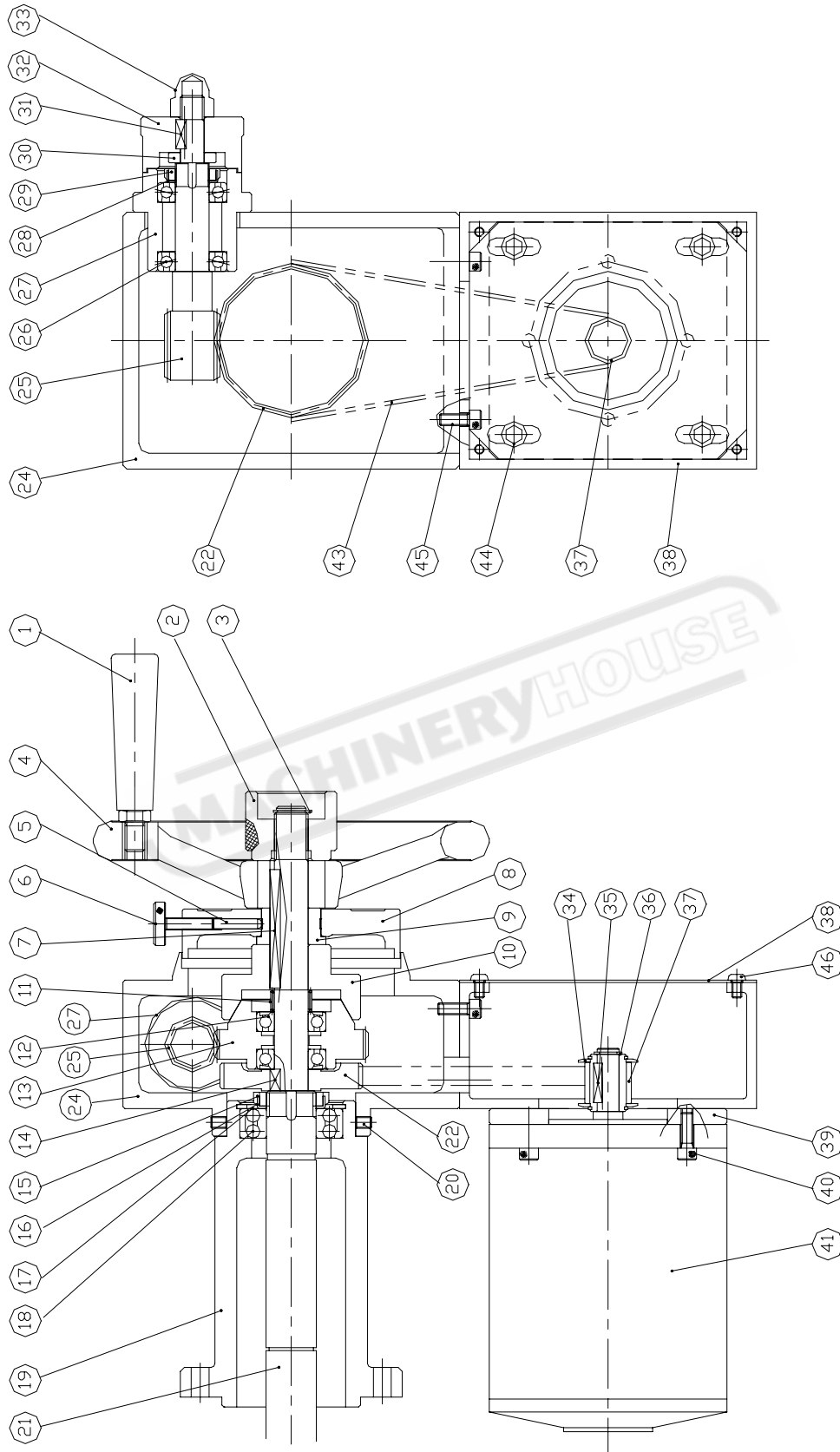

◎ Power rapid with micro feed for vertical Parts List  
(FOR 1545/2045/2550/C3060/D4080)

NO	Parts No.	Parts Name	Q
1	FR-90	Handwhel grip	1
2	MF25405	Nut	1
3	STW#15	C-shaped snap ring	1
4	KSP-250	Handwheel	1
5	251403	Set pin	1
6	251205	Set screw	1
7	5×5×60L	key	1
8	251401	Graduation dial	1
9	251202	Graduation dial bush	1
10	MF25404	Friction gear	1
11	251352	Spring	1
12	B-6003Z	Ball bearing	2
13	MF25403	Spiral gear	1
14	5×5×10L	Key	1
15	AN05	Chuck nut	1
16	AW05	Ratchet washer	1
17	STW#55	C-shaped snap ring	1
18	B-1205	Ball bearing	1
19	MF20400	Transmission shaft base	1
20	M6×P1.0×6L	Fixed screw	4
21	MF25401	Transmission shaft	1
22	RMF25430	Timing belt pulley	1
23	-	-	-
24	MF25402	Micro feed housing	1
25	MF25408	Micro feed worm	1
26	B-7003	Ball bearing	2
27	MF25407M	Worm bearing base	1
28	AW03	Ratchet washer	1
29	AN03	Chuck nut	1
30	MF25409	Set ring	1
31	5×5×15L	Key	1
32	MF25410M	Micro feed dial	1
33	M12×P1.75	Fixed screw	1
34	251233	Timing belt pulley cover	1
35	4×4×20L	Key	1
36	STW#11	C-shaped snap ring	1
37	251234	Timing belt pulley	1
38	RMF25431	Belt protection cover	1
39	DF25404	Motor fixed plate	1
40	M6×P1.0×15L	Fixed screw	4
41	1/5HP×6P	AC motor	1
42	-	-	-
43	T-187L037	Timing belt	1
44	M8×P1.25×10L	Fixed screw	4
45	M6×P1.0×15L	Fixed screw	2
46	M8×P1.25×10L	Fixed screw	4

19. M, H Micro cross feed Assembly Drawing (Optional accessory)

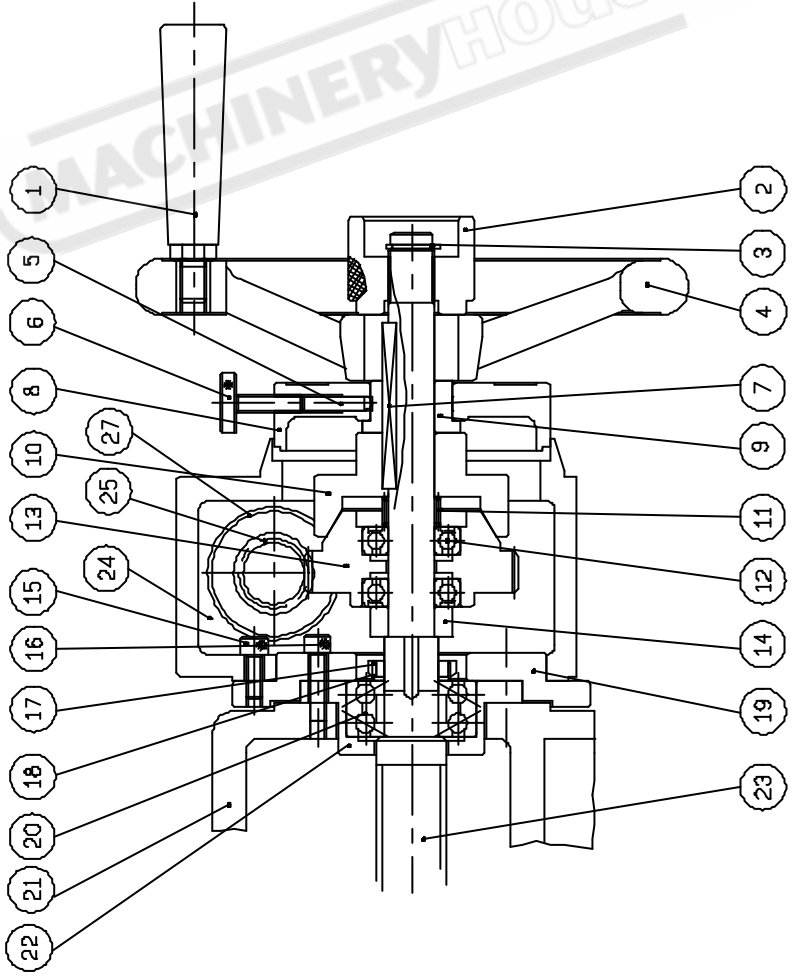
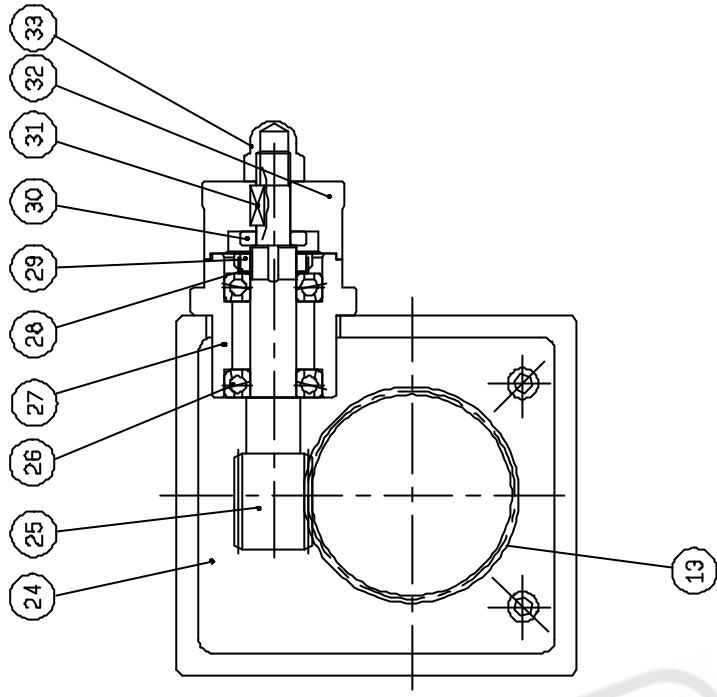

◎ M、H Micro cross feed Assembly Parts List

NO	Parts No.		Parts Name	Q
	C1545M/H C2045M/H	C2550H		
1	FN-80	FN-80 FG-90	Handwheel grip	1
2	MF25405	MF25405	Nut	1
3	STW#15	STW#15	C-shaped snap ring	1
4	KRN-160	KRN-200 KSP-200	Handwheel	1
5	251203	251203	Set pin	1
6	251205	251205	Set screw	1
7	5×5×60L	5×5×60L	Key	1
8	401201M	401201M	Graduation dial	1
9	251202	251202	Graduation dial bush	1
10	MF25404	MF25404	Friction gear	1
11	251352	251352	Spring	1
12	B-6003Z	B-6003Z	Ball bearing	2
13	MF25403	MF25403	Spiral gear	1
14	251410	251410	Dial washer	1
15	M6×P1.0×15L	M6×P1.0×15L	Fixed screw	3
16	M6×P1.0×25L	M6×P1.0×25L	Fixed screw	3
17	AN04	AN04	Check nut	1
18	AW04	AW04	Ratchet washer	1
19	MF20213	MF20213	Bearing holding	1
20	B-3204	B-3204	Ball bearing	1
21	201102	201102	Saddle	1
22	201206	201206	Bearing base	1
23	MF20211	MF20211	Ballscrew	1
24	MF25202	MF25202	Micro feed housing	1
25	MF25408	MF25408	Micro feed worm	1
26	B-7003	B-7003	Ball bearing	2
27	MF25407M	MF25407M	Worm bearing base	1
28	AW03	AW03	Ratchet washer	1
29	AN03	AN03	Chuck nut	1
30	MF25409	MF25409	Set ring	1
31	5×5×15L	5×5×15L	Key	1
32	MF25210M	MF25210M	Micro feed dial	1
33	M12×P1.75	M12×P1.75	Fixed screw	1

### 20. AH Micro cross feed Assembly Drawing (Optional Accessory)

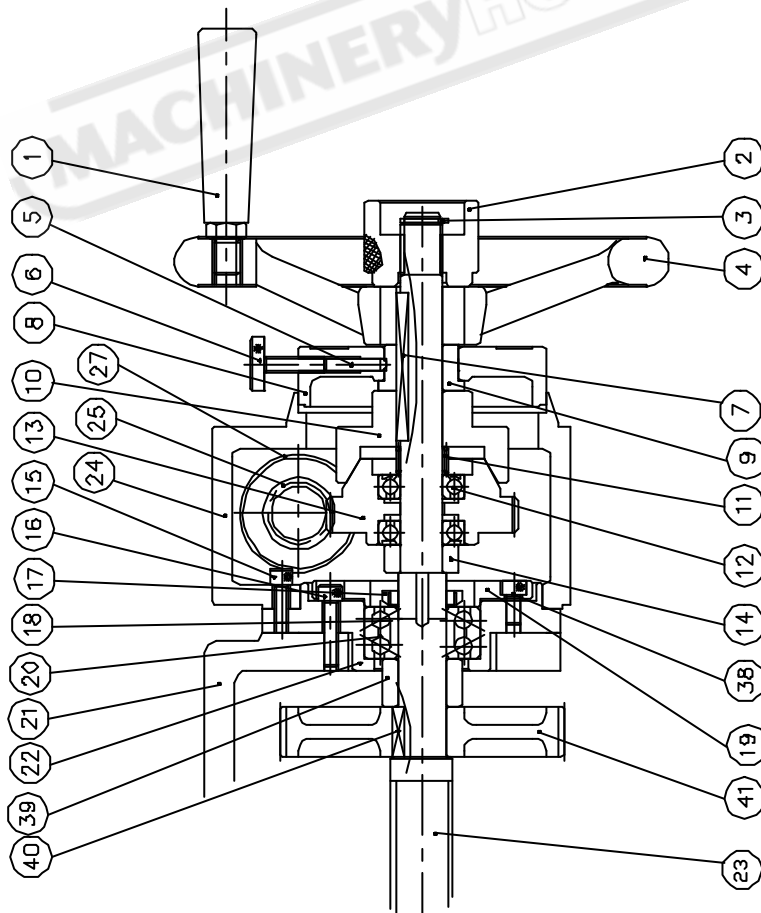
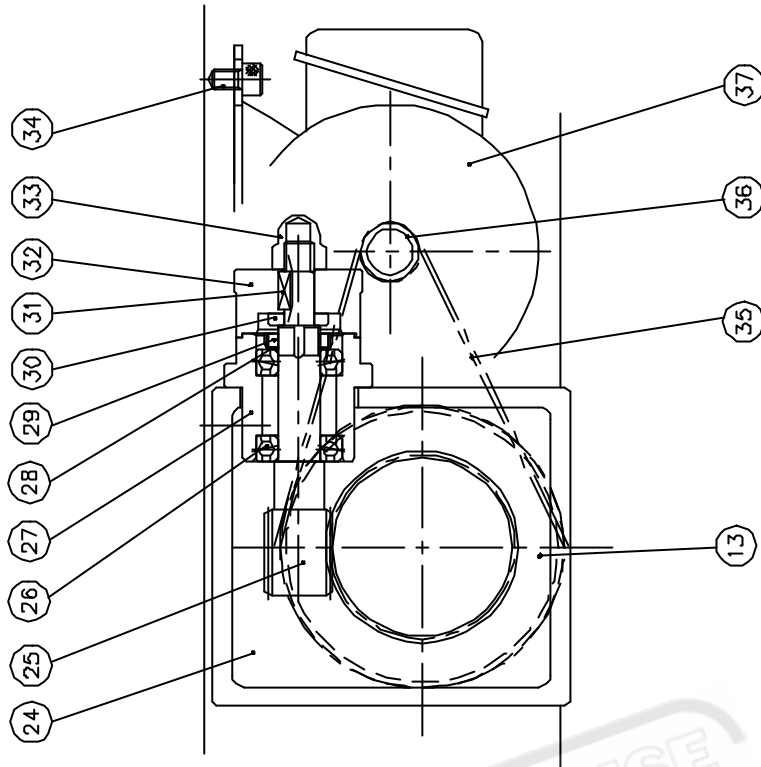

## AH Micro cross feed Assembly Parts List

NO	Parts No.	Parts Name	Q
1	FG-90	Handwheel grip	1
2	MF25405	Nut	1
3	STW#15	C-shaped snap ring	1
4	KSPT-200	Handwheel	1
5	251203	Set pin	1
6	251205	Set screw	1
7	5×5×60L	Key	1
8	401201M	Graduation dial	1
9	251202	Graduation dial bush	1
10	MF25404	Friction gear	1
11	251352	Spring	1
12	B-6003Z	Ball bearing	2
13	MF25403	Spiral gear	1
14	251410	Dial washer	1
15	M6×P1.0×15L	Fixed screw	3
16	M6×P1.0×25L	Fixed screw	3
17	AN04	Check nut	1
18	AW04	Ratchet washer	1
19	251206	Bearing holding	1
20	B-3204	Ball bearing	1
21	251102	Saddle	1
22	MF25213	Bearing base	1
23	MF25211	Ballscrew	1
24	MF25202	Micro feed housing	1
25	MF25408	Micro feed worm	1
26	B-7003	Ball bearing	2
27	MF25407M	Worm bearing base	1
28	AW03	Ratchet washer	1
29	AN03	Chuck nut	1
30	MF25409	Set ring	1
31	5×5×15L	Key	1
32	MF25210M	Micro feed dial	1
33	M12×P1.75	Fixed screw	1
34	M6×P1.0×12L	Fixed screw	3
35	B-187L075	Timing belt	1
36	251234	Timing belt pulley	1
37	1/5HP×6P	AC motor	1
38	M8×P1.25×12L	Fixed screw	3
39	251231	AH washer	1
40	5×5×20L	Key	1
41	251232	Timing belt pulley	1



# **SURFACE GRINDERS**

## **OPERATION MANUAL**

**TYPE-AD5  
AUTO. DOWN FEED**

**NC CONTROLLER**

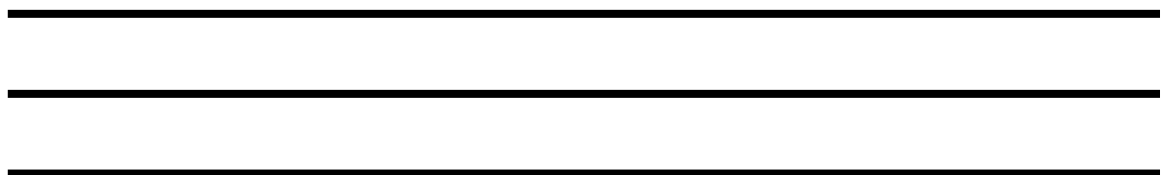

## TABLE OF CONTENTS







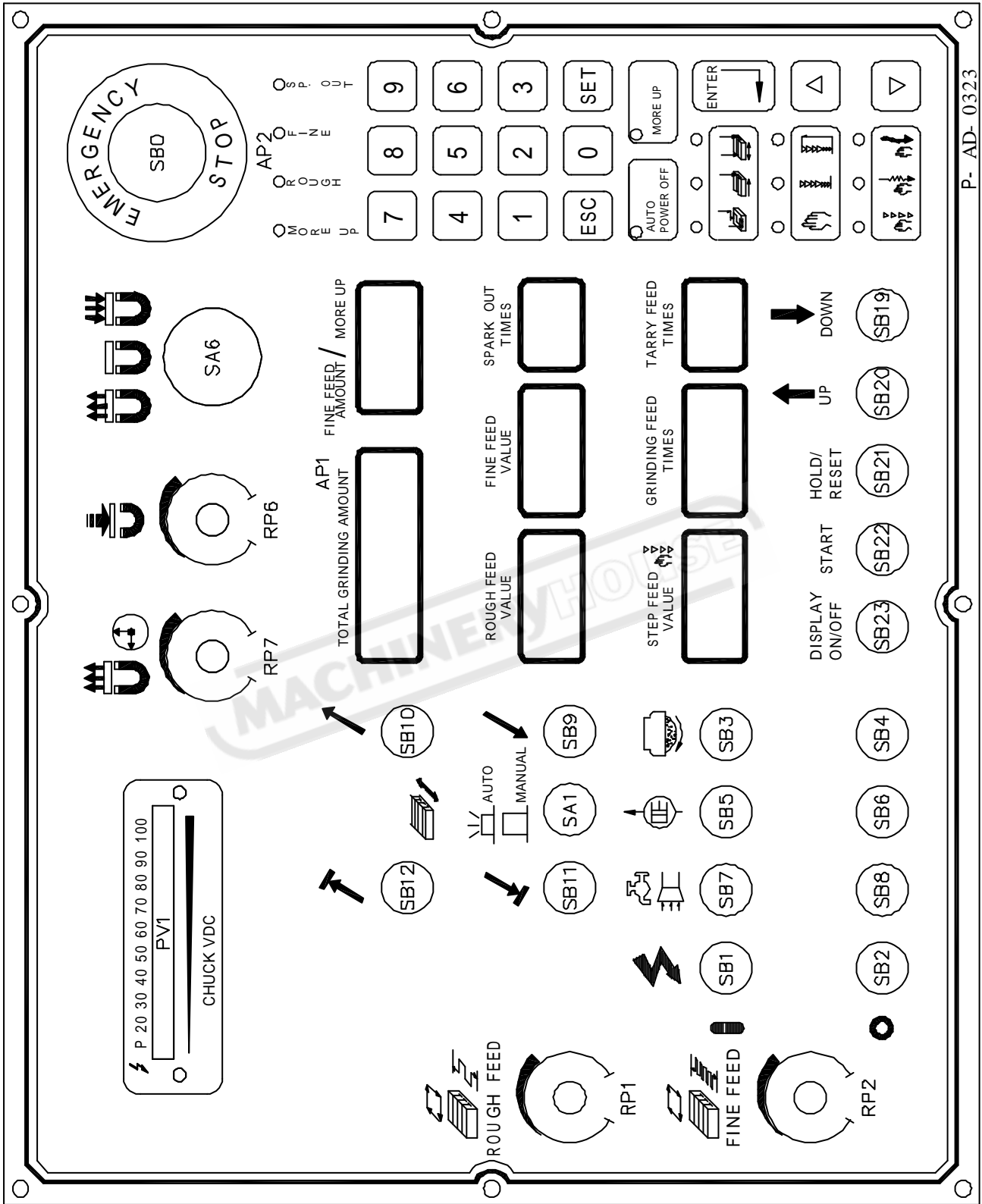







1. DIAGRAM FOR CONTROL PANEL.....	P. 01
2. EXPLANATION FOR CONTROL PANEL.....	P. 02
3. DESCRIPTION OF AUTO DEMAGNETIZED SWITCH.....	P. 09
4. EXPLAIN OF THE AUTO. DOWN FEED FUNCTIONS .....	P. 10
5. AUTO. DOWN FEED OPERATION .....	P. 11
6. CAUTION FOR OPERATION.....	P. 12
7. ERROR CODE .....	P. 13
8. CHECK INPUT POINT .....	P. 13
9. COMPLETE OPERATION PROCEDURE OF AD5.....	P. 14
10. ELECTRIC DIAGRAM.....	P. 16

MACHINERYHOUSE

# 1. DIAGRAM FOR CONTROL PANEL



## 2. EXPLANATION FOR CONTROL PANEL

<p><b>1</b></p>    <p>SA1</p>	<p><b>SA1: CROSS FEED AUTO OR MANUAL SELECTION.</b></p> <p>Pushed (the button is lighted) - automatic cross feed grinding.          Repush (the button light will be off) - manual mode.</p>
<p><b>2</b></p> <p><b>ROUGH FEED</b></p>   <p>RP1</p>	<p><b>RP1: ROUGH FEED SETTING ADJUSTMENT.</b></p> <p>(If the auto. down feed does not start, it is controlled by the cross feed value setting.)          (When down feed was started, it is controlled by the cross feed value setting of down feed with rough feed.)</p> <p>Increase at clockwise adjusting.          Decrease at counter-clockwise adjusting.</p>
<p><b>3</b></p> <p><b>FINE FEED</b></p>   <p>RP2</p>	<p><b>RP2: FINE FEED SETTING ADJUSTMENT.</b></p> <p>(If the auto. down feed does not start, it hasn't used.)          (When down feed was started, it is controlled by the cross feed times setting of fine feed.)</p> <p>Increase at clockwise adjusting.          Decrease at counter-clockwise adjusting.</p>
<p><b>4</b></p>  <p>SB0</p>	<p><b>SB0: EMERGENCY STOP BUTTON.</b></p> <p>To disconnect control power.</p>
<p><b>5</b></p>   <p>SB1</p>  <p>SB2</p>	<p><b>SB1: POWER ON BUTTON.</b></p> <p>To start control power.</p> <p><b>SB2: POWER OFF BUTTON.</b></p> <p>To stop control power.</p>
<p><b>6</b></p>   <p>SB3</p>  <p>SB4</p>	<p><b>SB3: SPINDLE START.</b></p> <p>To start spindle motor.</p> <p><b>SB4: SPINDLE SHUT OFF.</b></p> <p>To stop spindle motor.</p>

**7**

**SB5: HYDRAULIC SYSTEM ON.**  
To start hydraulic system motor.



SB5

**SB6: HYDRAULIC SYSTEM OFF.**  
To stop hydraulic system motor.



SB6

**8**

**SB7: COOLANT SYSTEM ON OR DUST SUCTION SYSTEM ON.**

To start coolant system motor or start dust suction system motor.



SB7

**SB8: COOLANT SYSTEM OFF OR DUST SUCTION SYSTEM OFF.**

To stop coolant system motor or stop dust suction system motor.



SB8

**9**

















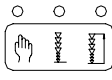

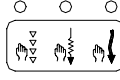
SB10

**SB10: TABLE MOVES BACKWARDS BUTTON.**  
To start cross feed motor to backward motion.

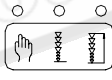

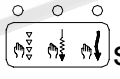
SB9

**SB9: TABLE MOVES FORWARDS BUTTON.**  
TO start cross feed motor to forward motion.

<p>10</p>		<p><b>SB12: CROSS TRAVEL SETTING TO ATUO. FORWARD POINT. (OPTION)</b> When push the “SB12”, it will be set cross travel to auto. forward point.</p>
	 <p>SB12</p>	
		<p><b>SB11: CROSS TRAVEL SETTING TO ATUO. BACKWRAD POINT. (OPTION)</b> When push the “SB11”, it will be set cross travel to auto. backward point.</p>
	 <p>SB11</p>	
<p>11</p>	 <p>DOWN</p>  <p>SB19</p>	<p><b>SB19: WHEEL HEAD DOWN PUSH BUTTON. (MANUAL)</b></p> <p>a. This function must follow  position.  to be preset in  position.</p> <p>b. Select  switch to control wheel head down mode firstly.</p>
<p>12</p>	 <p>UP</p>  <p>SB20</p>	<p><b>SB20: WHEEL HEAD UP PUSH BUTTON. (MANUAL)</b></p> <p>a. This function must follow  position.  to be preset in  position.</p> <p>b. Select  switch to control wheel head up mode firstly.</p>
<p>13</p>	 <p>START</p>  <p>SB22</p>	<p><b>SB22: AUTO. DOWN FEED START PUSH BUTTON.</b> Push (SB22) to start auto. down feed function.</p>
<p>14</p>	 <p>DISPLAY</p>  <p>SB23</p>	<p><b>SB23: DISPLAY LED START PUSH BUTTON.</b> Push (SB23) (LED lighted) to start LED display, and the auto. down feed function ready to work.</p>

15



SB21: HOLD OR TO CANCEL AUTO. DOWN FEED FUNCTION PUSH BUTTON.

When auto. down feed working, it can be paused by the HOLD button (SB21).

1. While it is in HOLD mode push the START button (SB22), then the auto. down feed will be continue.
2. While it is in HOLD mode push the (SB21) again to be cancel auto. down feed function.

16

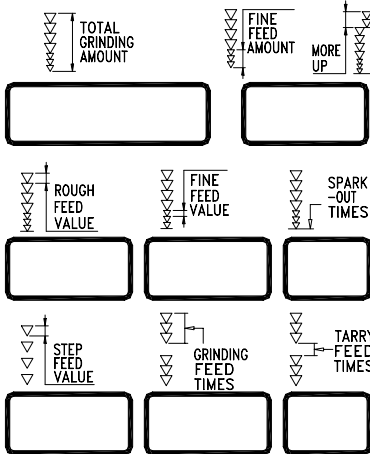

AP1: AUTO. DOWN FEED VALUE DISPLAY.

To display grinding amount, feed value and feed times.

a

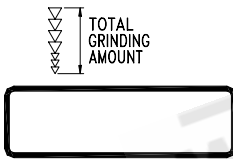

DOWN FEED AMOUNT INDICATOR.

To display total grinding amount before grinding, and to decrease of the value when grinding, and show the remnants grinding amount.

b

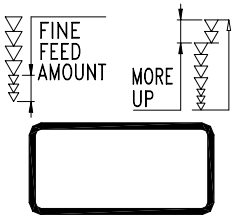

a. FINE FEED AMOUNT INDICATOR.

b. MORE UP INDICATOR.

When machine is working, that is showing the fine feed amount.

WHEN SETTING:

a. This is a fine feed amount setting, when more up function was be off.





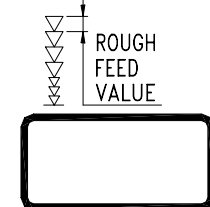





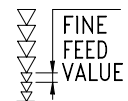

b. This is a more up setting, when more up function is running.

c

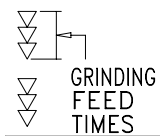

ROUGH FEED VALUE INDICATOR.

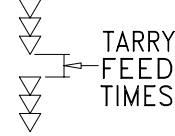
Setup of value of rough feed per time

<p><b>d</b></p>  	<p><b>FINE FEED VALUE INDICATOR.</b> Setup of value of fine feed per time.</p>
<p><b>e</b></p>  	<p><b>SPARK-OUT TIMES INDICATOR.</b> Setup of times of running without feeding.</p>
<p><b>f</b></p>  	<p><b>STEP-FEED VALUE INDICATOR.</b> Press  on manual mode and  press on step feed mode to set up step feed value. For example, press 1 shown on  which means 0.001 and press either up/down (SB20/SB19) that it will feed 0.001mm.</p>
<p><b>g</b></p>  	<p><b>GRINDING FEED TIMES INDICATOR.</b> Stop auto down feeding after certain times of feeding shown on the screen and continue feeding after “ h ” running. For example, it is set as 5 times, h as 3 times. It will run 5 times and stop to run for 3 times without feeding. And then continue running 5 times (6-10 times totally) and stop feeding but running for 3 times...repeat again.</p>
<p><b>h</b></p>  	<p><b>TARRY FEED TIMES INDICATOR.</b> The setup of running times without feeding after “ g ” stopping feeding.</p>

NOTE: The setup of “ g, h ” is the setup of spark out of auto down feed, which will make up the feed suspension.

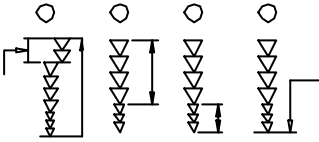

**17**  **AP2: DOWN FEED GRINDING SETTING PANEL.**

To preset the working condition and be set according to operator's desire.

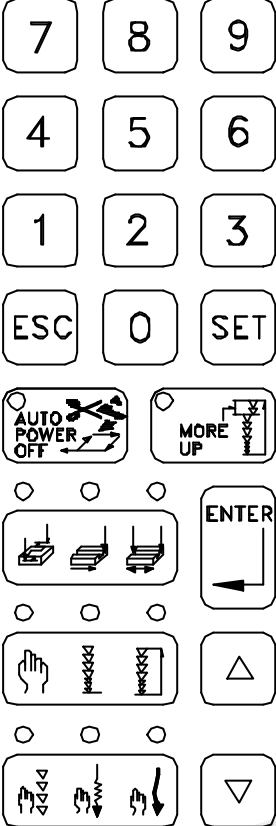

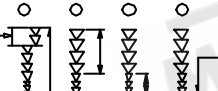
**a**  **DOWN FEED GRINDING VALUE SETTING PANEL.**

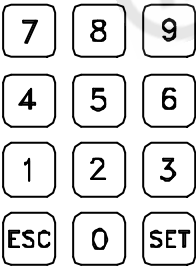

**SET** SET KEY: Press this key to change any setting value.



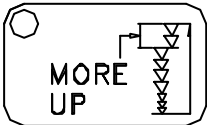



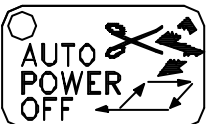



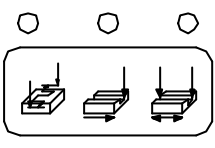

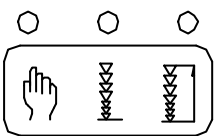

**ESC** EXIT KEY: When setting finished, press this key to exit the setting mode.

**b**  **MORE UP SETTING BUTTON.**

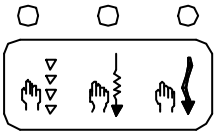
When auto. down feed finished, wheel head will be up to more than home position (start position), according to the setting value. The LED lights means the more up function is setting.

**c**  **AUTOMATIC POWER OFF SETTING BUTTON.**

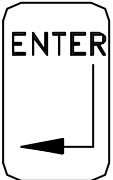
To setting auto. power off when auto. down feed was finished. The LED lights means the auto power off function is running.

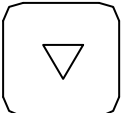
<p><b>d</b></p> 	<p><b>SURFACE AND PLUNGE (SINGLE-SIDE &amp; DOUBLE-SIDE) FUNCTION SELECTION BUTTON.</b></p> <p> is surface grinding mode. (only single-side)</p> <p> is plunge grinding single-side down feed mode.</p> <p> is plunge grinding double-side down feed mode.</p>
<p><b>e</b></p> 	<p><b>MANUAL, SEMI-AUTO, FULL-AUTO FUNCTION SELECTION BUTTON.</b></p> <p> is manual function.</p> <p>Based on those three modes of item “f” preset.</p> <p>Push (PB19) or (PB20) to move wheel head descend or rise.</p> <p> is semi-auto function.</p> <p>Auto. down feed finished, wheel head keep stop with finish position.</p> <p> is full-auto function.</p> <p>Auto. down feed finished, wheel head will up to home position. (start position)</p> <p>In more up function running. Auto. down feed finished. Wheel head will up to more up position.</p>
<p><b>f</b></p> 	<p><b>STEP-SPEED, LOW-SPEED, HIGH-SPEED FUNCTION SELECTION BUTTON.</b></p> <p>This function must follow item “e” to be preset in  position.</p> <p> is step-feed mode.</p> <p> is low-speed mode.</p> <p> is high-speed mode.</p>
<p><b>g</b></p> 	<p><b>TO MAKE SURE THE SETTING VALUE.</b></p>
<p><b>h</b></p> 	<p><b>SETTING INDICATOR SELECTION.</b></p>
<p><b>i</b></p> 	<p><b>SETTING INDICATOR SELECTION.</b></p>



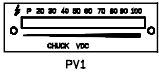
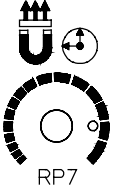
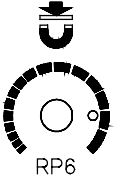
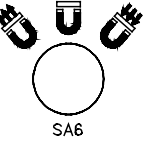



### 3. DESCRIPTION OF AUTO DEMAGNETIZED SWITCH

<p><b>1</b></p> 	<p><b>PV1: ELECTROMAGNETIC CHUCK LAMP.</b> Lights are display for the electromagnetic chuck voltage.</p>
<p><b>2</b></p> 	<p><b>RP7: DEMAGNETIZATION TIME ADJUSTMENT.</b> Increase at clockwise adjusting. Decrease at counter-clockwise adjusting.</p>
<p><b>3</b></p> 	<p><b>RP6: MAGNETIZED VOLTAGE ADJUSTMENT.</b> Increase at clockwise adjusting. Decrease at counter-clockwise adjusting.</p>
<p><b>4</b></p> 	<p><b>SA6: MAGNETIC SELECTION SWITCH.</b> Left-demagnetized. Middle-lack of magnetic force. Right-magnetized.</p>

MACHINERYHOUSE

## 4. EXPLAIN OF THE AUTO. DOWN FEED FUNCTIONS

### (1) Keyboard settings:

- ① When setting the value, it can press the  key of the AP2.
- ② Then the AP1 value indicator will be light, and it can used   key to select working condition and functions.
- ③ Use the AP2 keypad key-in the numbers. (UNIT:0.001MM) (In inch specification UNIT:0.0001")
- ④ When key-in finished, press  to make the working value, then the AP1 indicator will be skip to next setting condition. (It can be setting or changing the numerical value, or press the  to cancel this setting value.)
- ⑤ To end the program function, please push the  key or repress  key again to exit the setting mode.





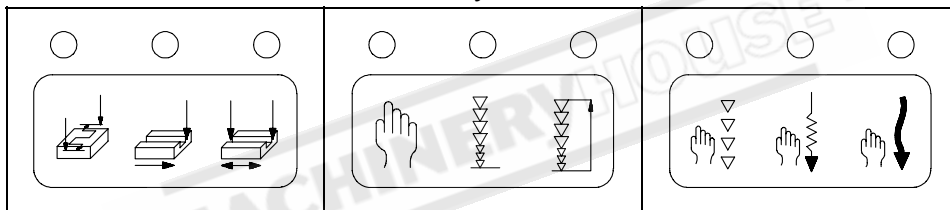

### (2) Explain of the function key in setting mode:

- ① There have three function keys in AP2 :





- ② Press the function key, the LED will display at present.
- ③ Use the AP2 function key, to change working mode. (\* When the LED lights ON it is mean the working function now.)









### (3) More up setting:

- ① Under AP2, please push the  key, and press the  setting key, then the wheel head will be more up than home position when auto. down feed was finished.
- ② Use the AP2 keypad to key-in the number of the more up value. (UNIT:0.001MM) (In inch specification UNIT:0.0001")
- ③ When finished, please push  key to make sure the key-in value or press  key to cancel the setting value, and keep the front setting value.
- ④ To end the program function, please push the  key or repress  key to exit the setting mode.

### (4) Wheel head up/down (step-feed · low-speed · high-speed) operation:





- ① This function must follow  to preset in  position.
- ② Use the  to select step-feed · low-speed · high-speed mode.
- ③ Push the SB19 or SB20 to descend or rise the wheel head.

#### (5) Step-feed setting in manual mode:

- ① Firstly, the  function key must be select in  mode.
- ② Use the  function key to select in  mode.
- ③ Press  key, and the AP1 of the **STEP FEED VALUE** LED will be light.
- ④ Use the AP2 keypad key-in the numbers. (UNIT:0.001MM) (In inch specification UNIT:0.0001")
- ⑤ When finished, please push  key to make sure the key-in value or press  key to cancel the setting value, and keep the front setting value.
- ⑥ To end the program function, please push the  key or repress  key to exit the setting mode.



## 5. AUTO. DOWN FEED OPERATION

### (1) Surface grinding:

- ① Base on the aforesaid, and setting the value to need. (UNIT:0.001MM) (In inch specification UNIT:0.0001")
- ② Use  function key to select in surface grinding mode.
- ③ Use  function key to set when grinding finished, the wheel head will stop in finish position or raise wheel head.
- ④ Turn the spindle motor SB3 and hydraulic system motor SB5 to ON.
- ⑤ Turn the hand wheel or press the  function key to select in  step-feed mode, and push SB19 to down, let the grinding wheel touch the workpiece.
- ⑥ Push the START button SB22 to do down feed working.

### (2) Plunge grinding:

- ① Base on the aforesaid, and setting the value to need. (UNIT:0.001MM) (In inch specification UNIT:0.0001")
- ② Use the  function key to select single-side or double-side. (\* At same time the cross control will be auto. off, and unable control to prevent the dangerous.)

- ③ Use  function key to set when grinding finished, the wheel head will stop in finish position or raise wheel head.
- ④ Turn the spindle motor SB3 and hydraulic system motor SB5 to ON.
- ⑤ Turn the hand wheel or press the  function key to select in  step-feed mode, and push SB19 to down, let the grinding wheel touch the workpiece.
- ⑥ Push the START button SB22 to do down feed working.



(3) Pause the working when grinding:

- ① If needs to be stopped, push (HOLD/RESET) button (SB21) to temporarily stop, at same time the (HOLD/RESET) button will be lights.
- ② While it is in HOLD mode push the START button (SB22), then the auto. down feed will be continue.
- ③ While it is in HOLD mode push the (SB21) again to be cancel auto. down feed function.

(4) Auto. power off function:

- ① Press the  AUTO POWER OFF key, the LED lights, it means the auto power off was be setting.
- ② Then the auto. down feed working finished and it will be automatic power off.

(5) More up function:

- ① Under AP2 preset the  MORE UP key, the LED lights, it means the more up was be setting.
- ② It can used the key-pad of AP2 key-in the numbers.
- ③ When grinding finished, wheel head will be up more than home position(start position) to according to the setting value.
- ④ If want to clean the setting value. reset the  MORE UP key to cancel the more up function.

## 6. CAUTION FOR OPERATION

- (1) When the magnetic switch was not select right to chuck control, and the hydraulic system motor can not be started.
- (2) When the spindle does not rotated, the auto. down feed can not be started.
- (3) If no use the AP1 of the **GRINDING FEED TIMES** function, it can be setting to zero form **GRINDING FEED TIMES** and **TARRY FEED TIMES**.

## 7. ERROR CODE

Error code	Description
E-00	The spindle does not start.
E-01	The wheel head is up to limit position.
E-02	The value is not setting correctly.

## 8. CHECK INPUT POINT FOUNDCTION

\* This function is used to maintenance.

- (1) Press (DISPLAY) SB23 button to turn off, and it can be indicator in off condition.
- (2) Press (HOLD /RESET) SB21 button, and check input point will display in indicator.
- (3) The following is shown the check point position:

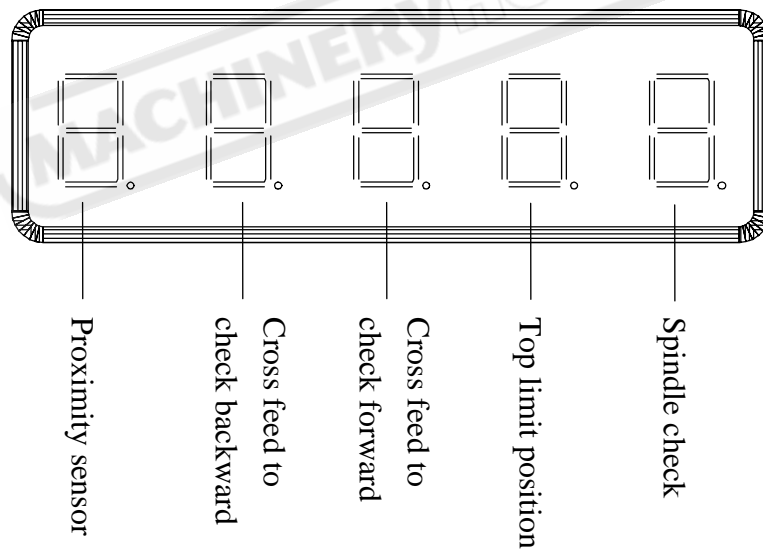

0 = No a signal to check

1 = Have a signal to check

- (4) When checking finished, please preset (DISPLALY) SB23 button to start, and return to working condition.

## 9. Complete Operation Procedure of AD5

AHR (X, Y axes auto, Z axis power rapid)

A: auto cross feed

H: auto longitudinal ravel by hydraulic

R: power rapid (Z axis) (AC motor installed on top of column)

AHR + AD5 (NC auto down feed for Z axis) as follows:

Operation procedures:

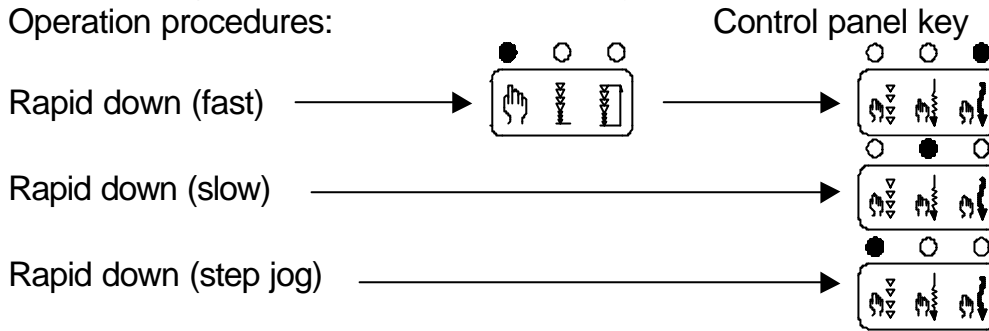



Touch work piece

Setup of AP1 of grinding value:

Screen from a-h on AP1, AP2

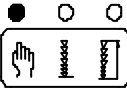
- a. Total grinding amount (EX: 0.0250", key in 250)  
Set -- , please see manual book on page 11.
- b. Fine feed amount (EX: 0.0005")  
Total rough amount 0.0245 (a-b, 0.0250-0.0005=0.0245")
- c. Rough feed per one time (EX: 0.002"/per time)  
0.0245-0.002" =13 times)
- d. Fine feed per one time (EX: 0.0001"/per time)  
0.0005-0.0001" =5 times)
- e. Spark out times (EX: 2 times)  
Total feeding time=13+5=18times)
- f. Step feed value is to set up jog feed.

First push  for manual mode. Second, push  for jog then push SB19/SB20 for down/up. It means when set up 1 on it, it downs to 0.0001".

g. 0004



h. 003

Every 4 times of feeding it will stop feeding and proceed to do tarry feed 3 times for example. After complete one cycle, it keeps feeding the next one.

The complete procedure of feeding displayed as follows:

**Step 1.**

#1 rough down "c" (0.002) #2 rough down "c" (0.002) #3 rough down "c" (0.002) #4 rough down "c" (0.002) stop down feed.

**Step 2.**

"h" tarry feed 3times #5 rough down "c" (0.002) #6 rough down "c" (0.002") #7 rough down "c" (0.002") #8 rough down "c" (0.002) stop down feed.

**Step 3.**

"h" tarry feed 3times #9 rough down "c" (0.002) #10 rough down "c" (0.002") #11 rough down "c" (0.002") #12 rough down "c" (0.002) stop down feed.

**Step 4.**

"h" tarry feed 3times #13 rough down "c" (0.002) #14 fine down "d" (0.0001") #15 fine down "d" (0.0001") #16 fine down "d" (0.0001") stop down feed.

**Step 5.**

"h" tarry feed 3times #17 fine down "d" (0.0001") #18 fine down "d" (0.0001").

note: total 18 times feeding.

**Step 6.**

spark out "e" (0.0001") 2 times.

## 10. ELECTRIC DIAGRAM

### CONTENTS

1) 1545/2045/2550/3060AH .....	P. 17
2) D2550/D3060/D4080AH.....	P. 18
3) DL2550/DL3060/DL4080AH.....	P. 19
4) AUTO DOWN FEED CIRCUIT DIAGRAM .....	P. 20
5) 50100~70200AHR(AC servo motor & operated manual by MPG) .....	P. 21

#### D TYPE:

1. Table longitudinal travel by sensor & solenoid valve.
2. Continuous lubrication.

#### DL TYPE:

1. Table longitudinal travel by sensor & solenoid valve.
2. Auto. crossing stroke adjustment by control panel switch.
3. Back water splash shield.
4. Continuous lubrication.

MACHINERYHOUSE

For 1545/2045/2550/CL3060AH

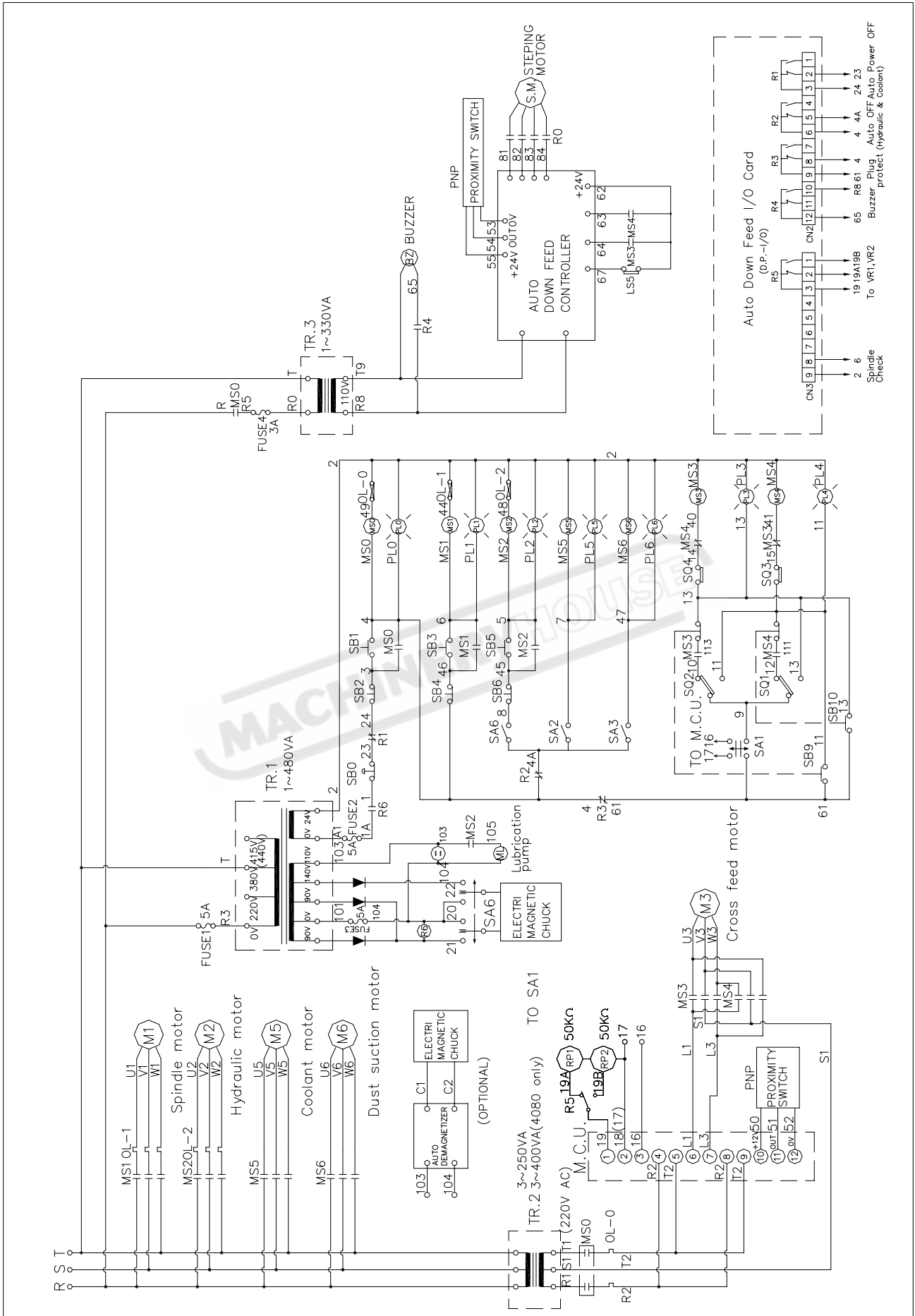

For D2550/D3060/D4080AH

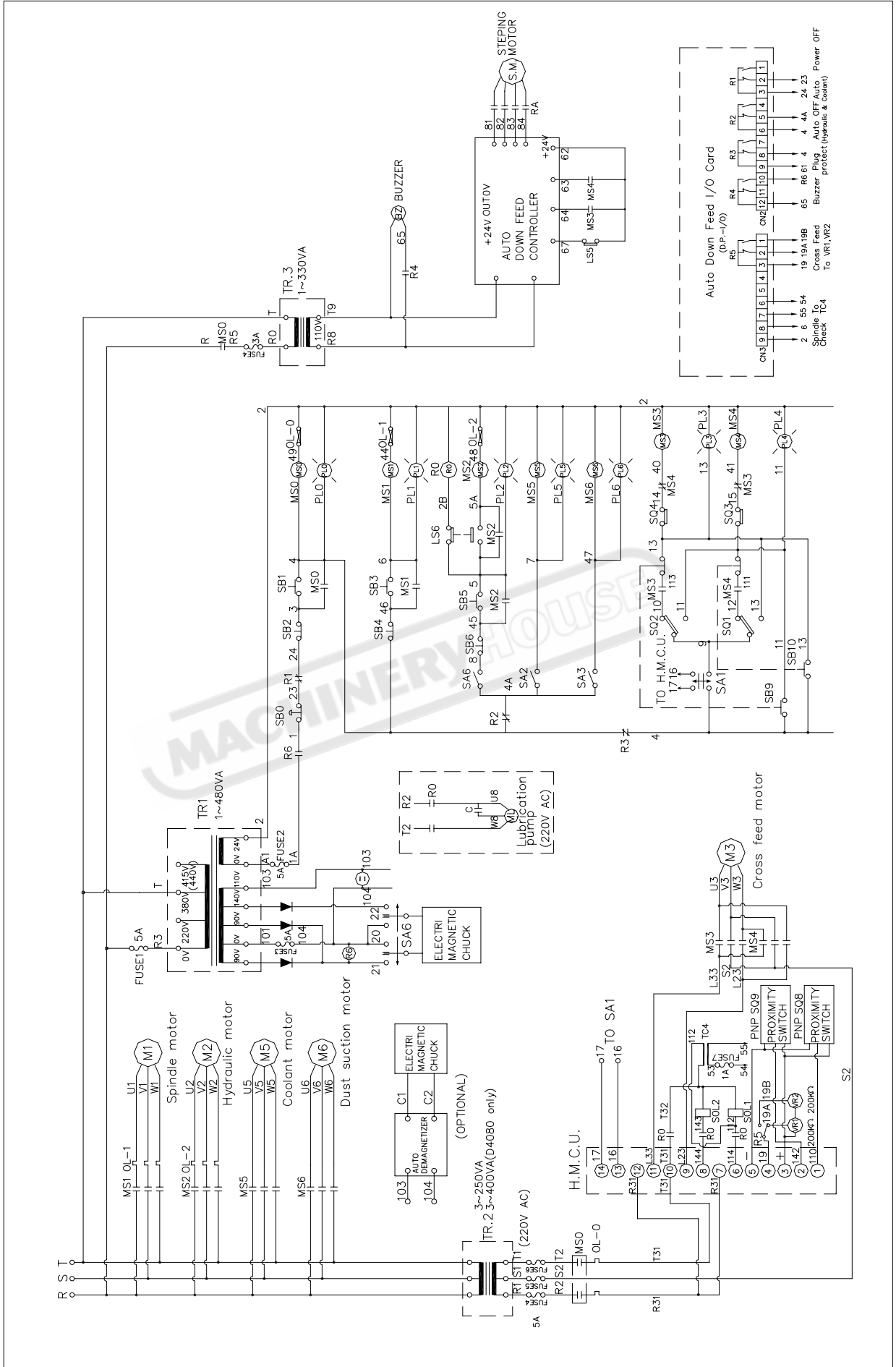

For DL2550/DL3060/DL4080AH

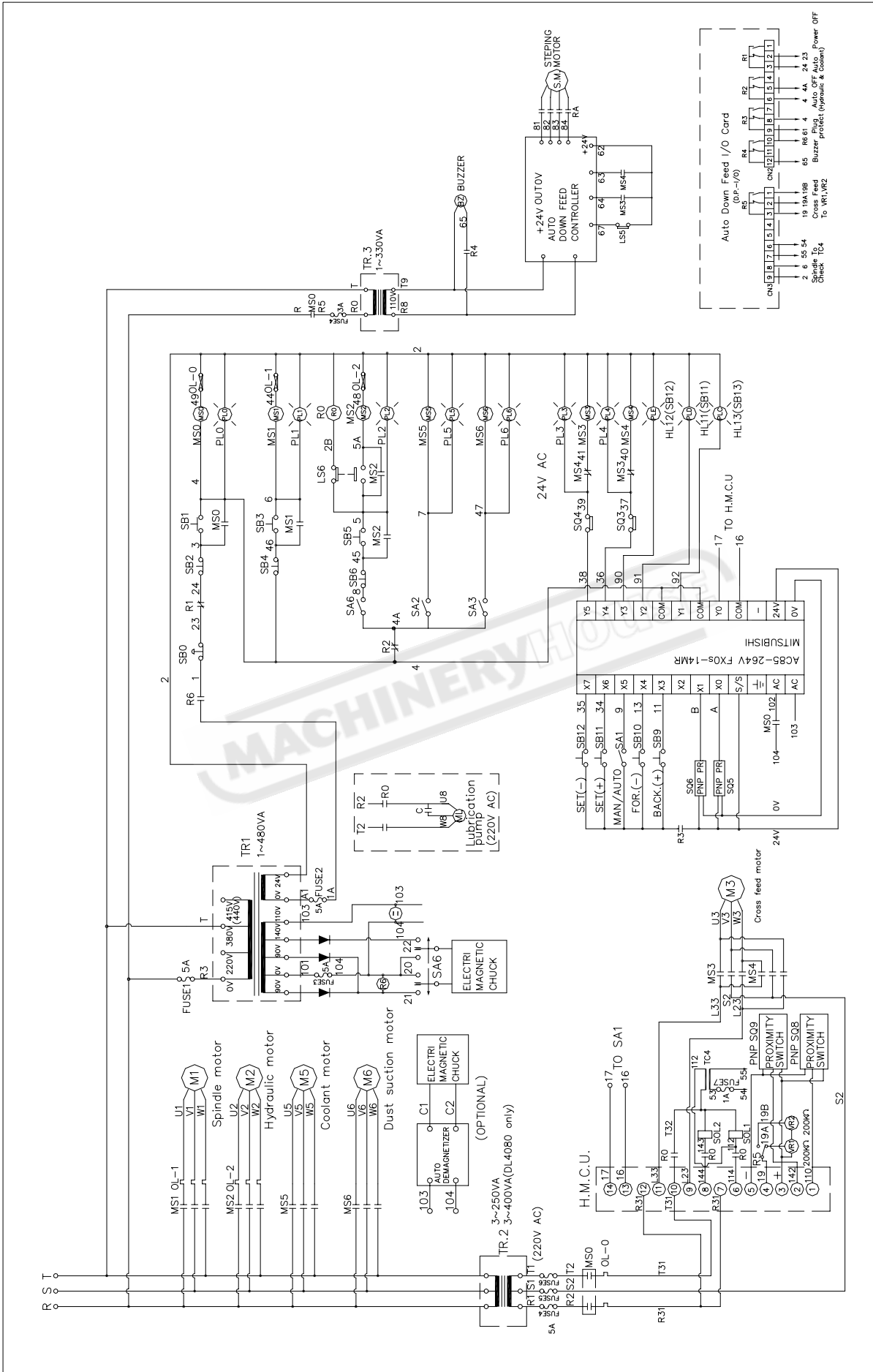

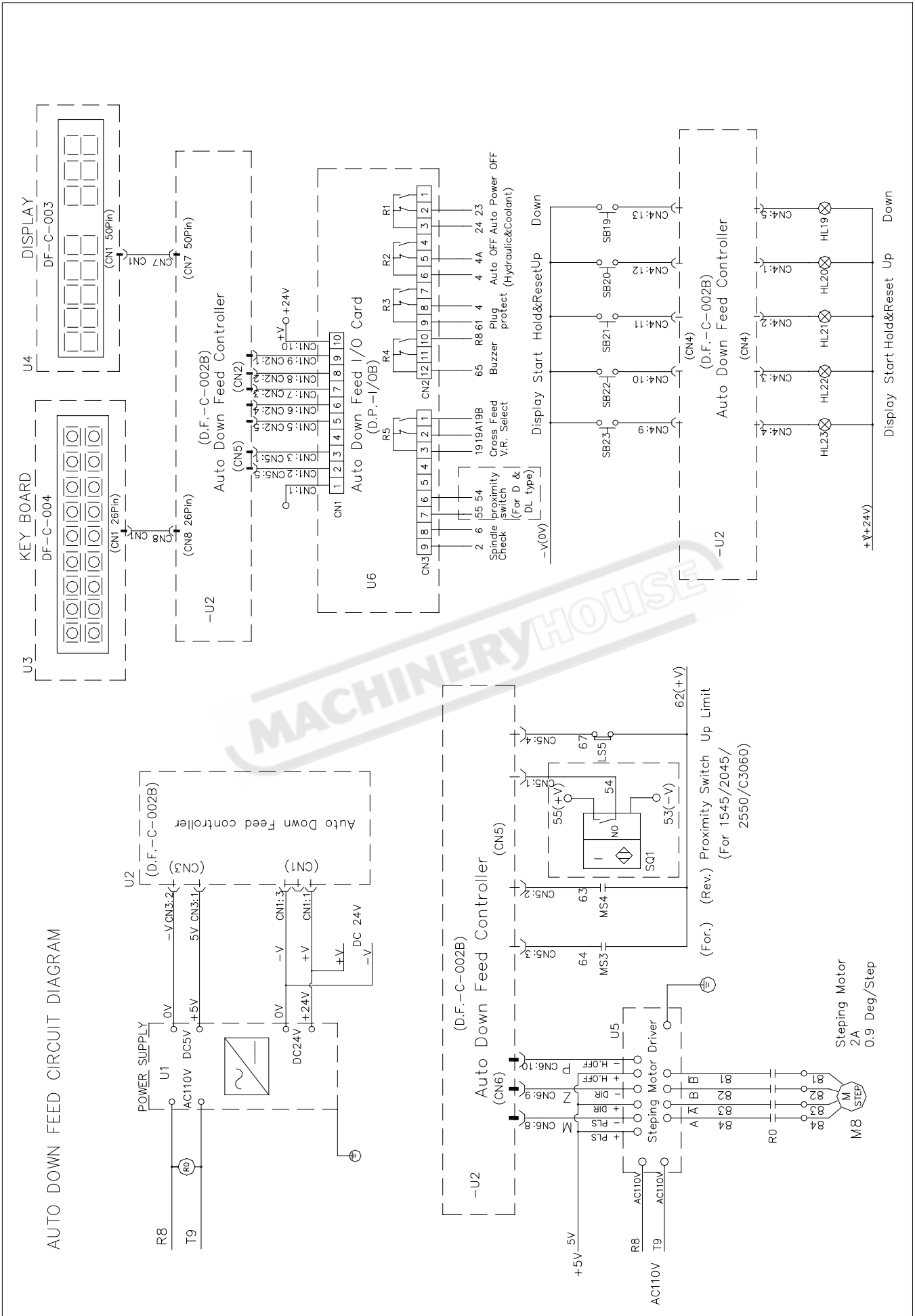

50100AHR~70200AHR(Vertical by MPG handwheel & AC servo motor)

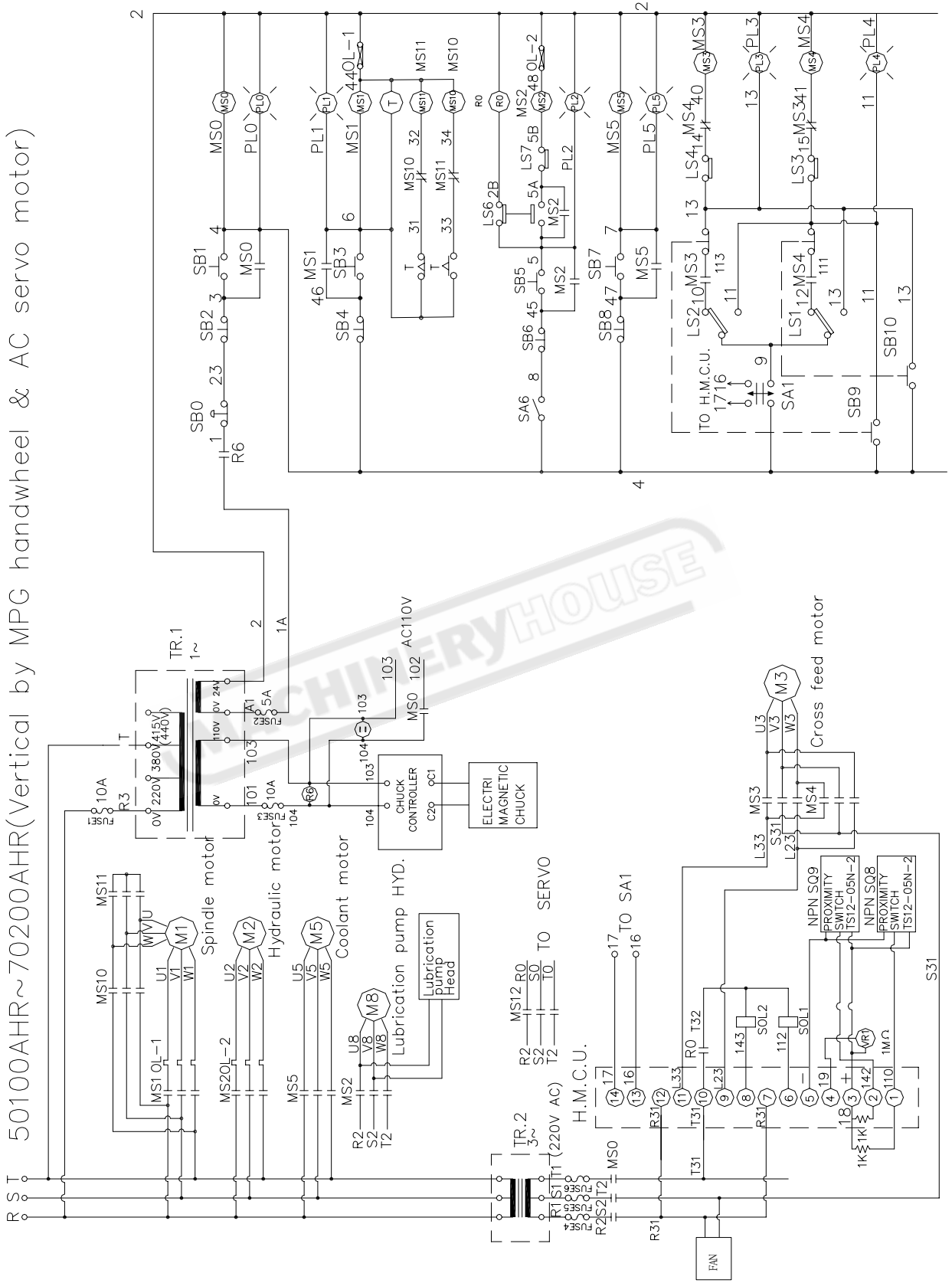

### AUTO DOWN FEED CIRCUIT DIAGRAM

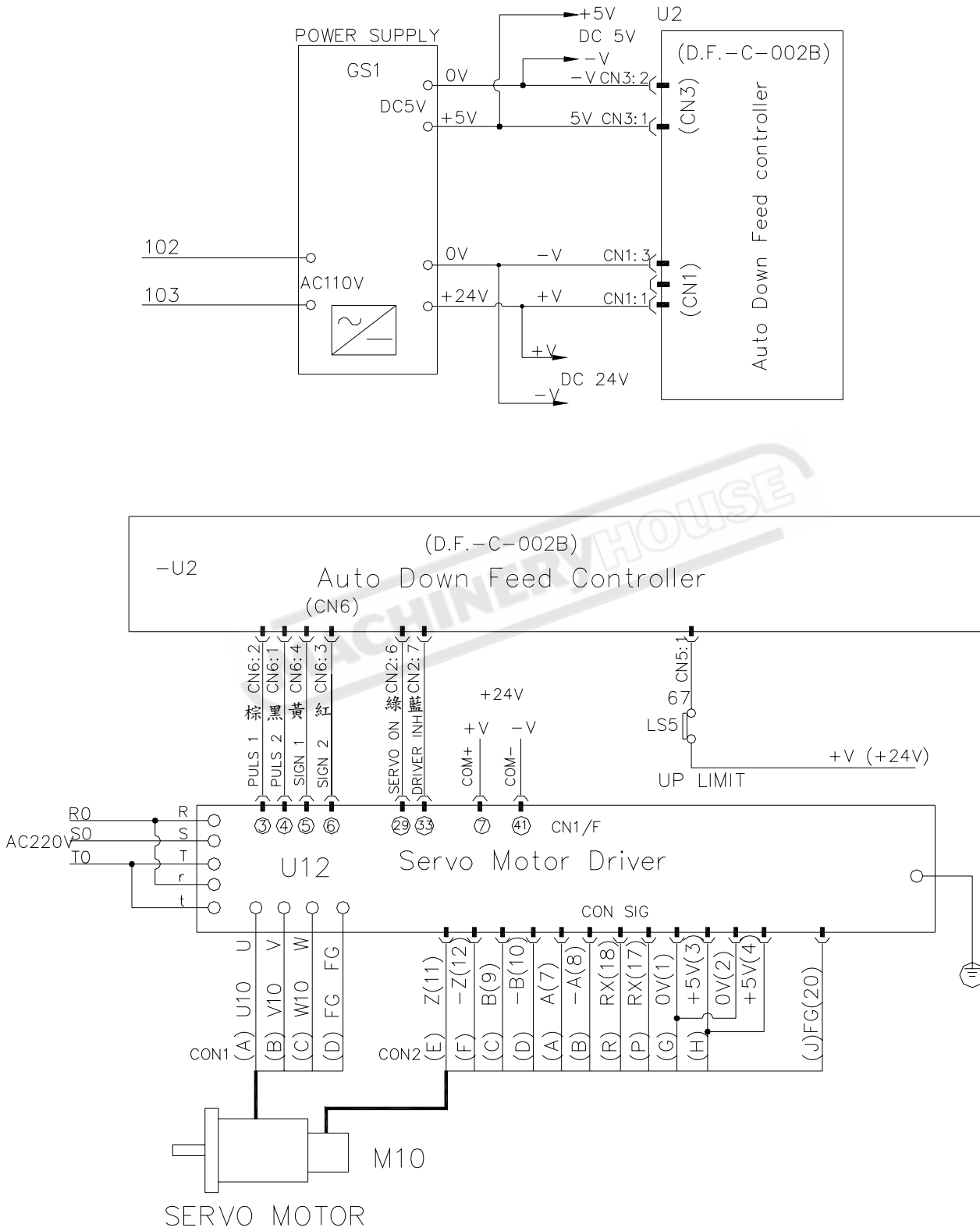



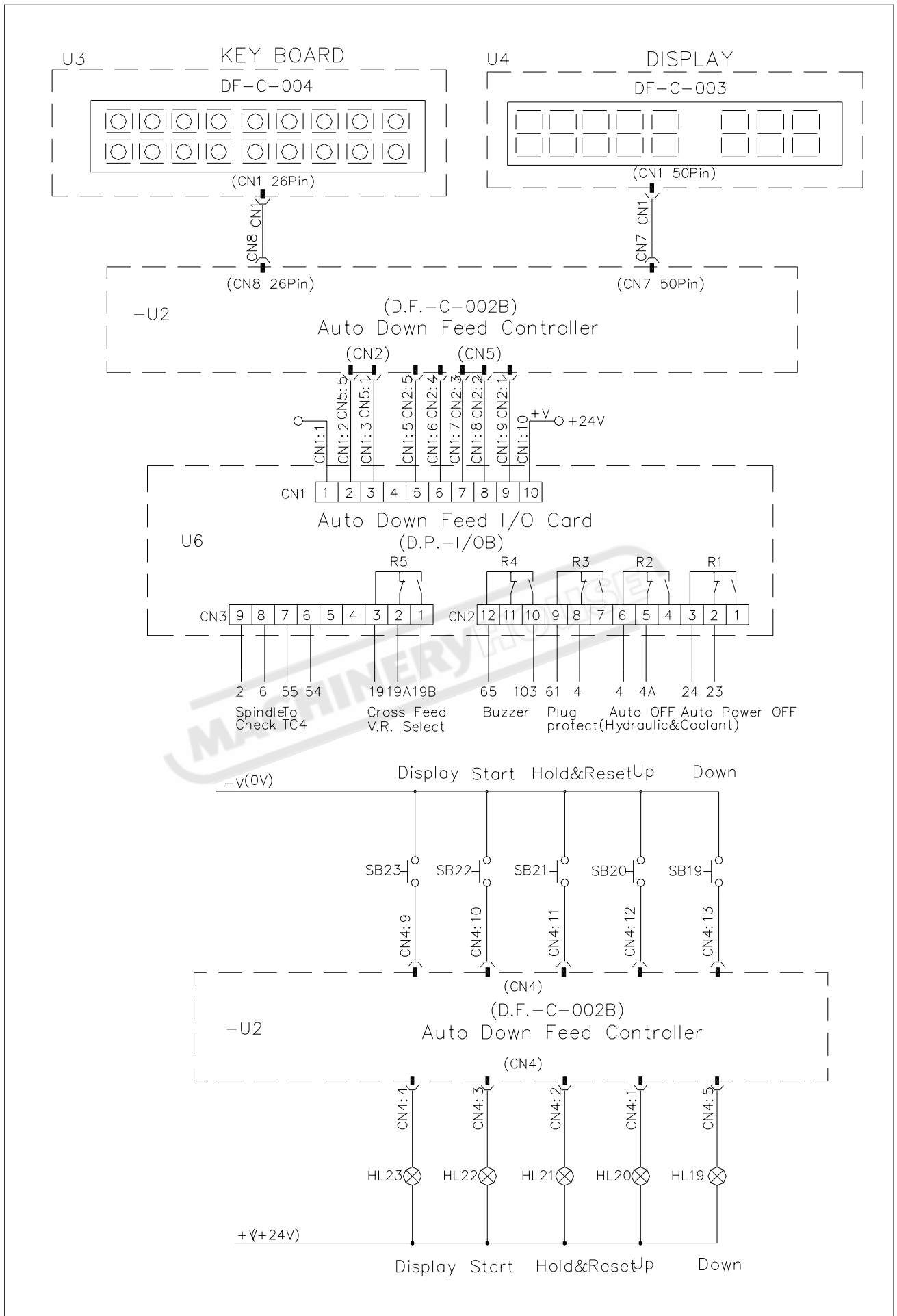

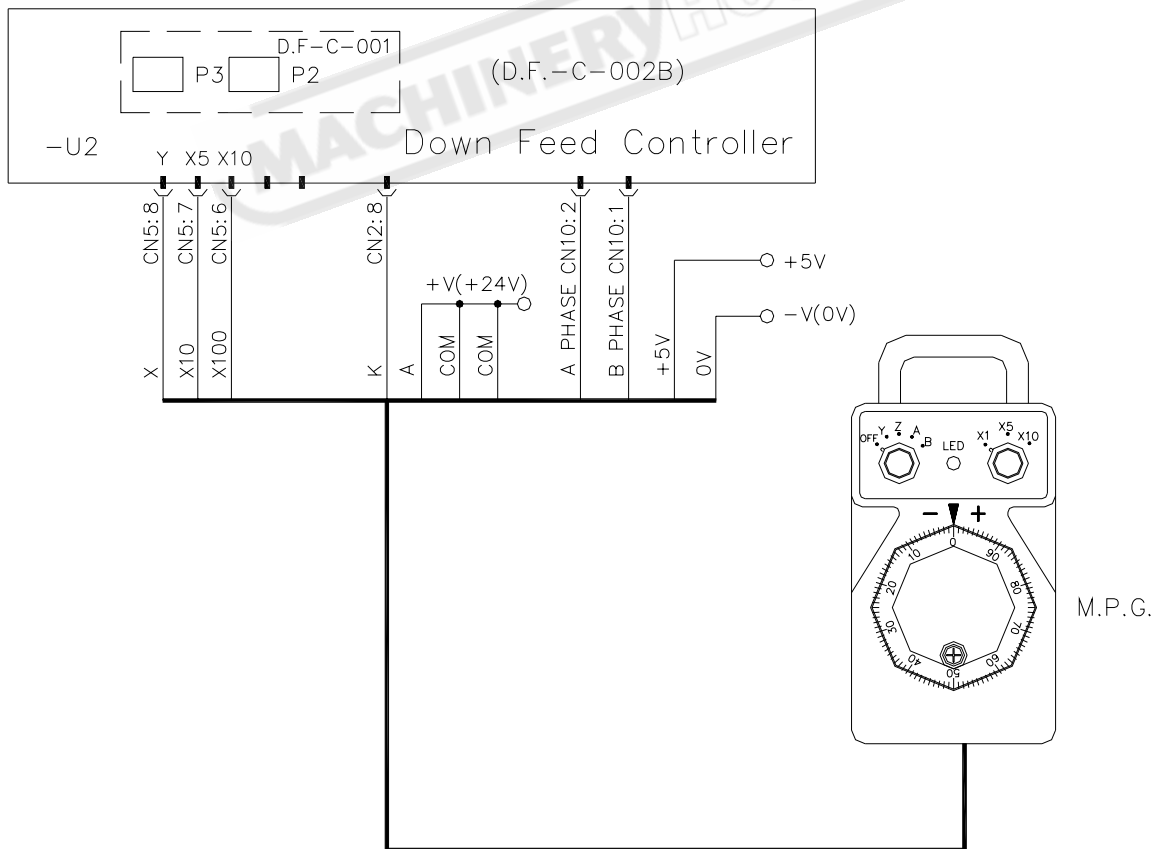
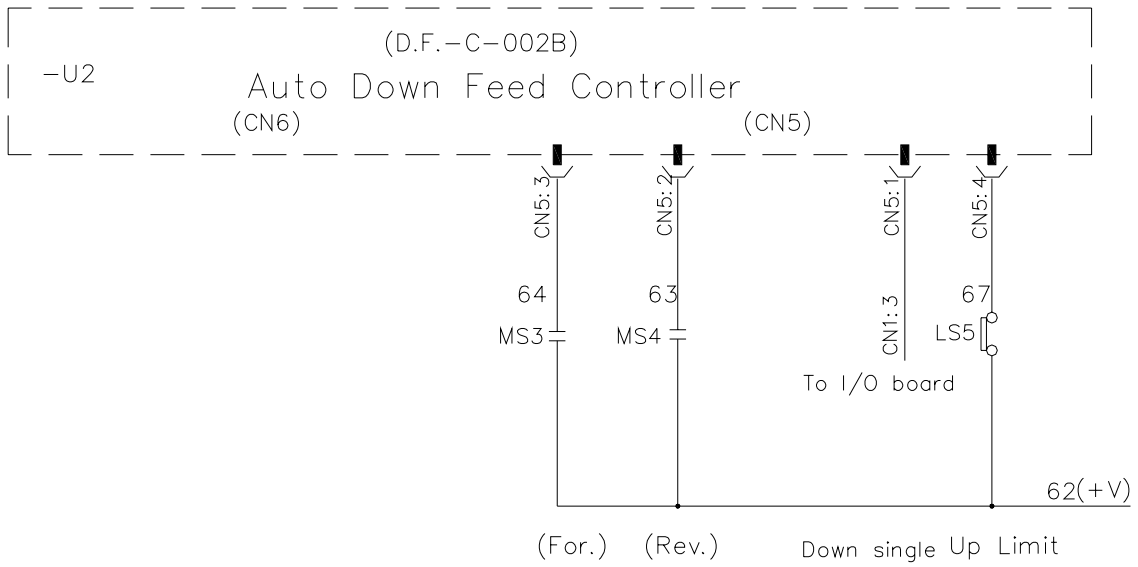



# WARNING

## General Machinery Safety Instructions

---

Machinery House  
requires you to read this entire Manual before using this machine.

- 1. Read the entire Manual before starting machinery.** Machinery may cause serious injury if not correctly used.
- 2. Always use correct hearing protection when operating machinery.** Machinery noise may cause permanent hearing damage.
- 3. Machinery must never be used when tired, or under the influence of drugs or alcohol.** When running machinery you must be alert at all times.
- 4. Wear correct Clothing.** At all times remove all loose clothing, necklaces, rings, jewelry, etc. Long hair must be contained in a hair net. Non-slip protective footwear must be worn.
- 5. Always wear correct respirators around fumes or dust when operating machinery.** Machinery fumes & dust can cause serious respiratory illness. Dust extractors must be used where applicable.
- 6. Always wear correct safety glasses.** When machining you must use the correct eye protection to prevent injuring your eyes.
- 7. Keep work clean and make sure you have good lighting.** Cluttered and dark shadows may cause accidents.
- 8. Personnel must be properly trained or well supervised when operating machinery.** Make sure you have clear and safe understanding of the machine you are operating.
- 9. Keep children and visitors away.** Make sure children and visitors are at a safe distance for you work area.
- 10. Keep your workshop childproof.** Use padlocks, Turn off master power switches and remove start switch keys.
- 11. Never leave machine unattended.** Turn power off and wait till machine has come to a complete stop before leaving the machine unattended.
- 12. Make a safe working environment.** Do not use machine in a damp, wet area, or where flammable or noxious fumes may exist.
- 13. Disconnect main power before service machine.** Make sure power switch is in the off position before re-connecting.
- 14. Use correct amperage extension cords.** Undersized extension cords overheat and lose power. Replace extension cords if they become damaged.
- 15. Keep machine well maintained.** Keep blades sharp and clean for best and safest performance. Follow instructions when lubricating and changing accessories.
- 16. Keep machine well guarded.** Make sure guards on machine are in place and are all working correctly.
- 17. Do not overreach.** Keep proper footing and balance at all times.
- 18. Secure workpiece.** Use clamps or a vice to hold the workpiece where practical. Keeping the workpiece secure will free up your hand to operate the machine and will protect hand from injury.
- 19. Check machine over before operating.** Check machine for damaged parts, loose bolts, Keys and wrenches left on machine and any other conditions that may effect the machines operation. Repair and replace damaged parts.
- 20. Use recommended accessories.** Refer to instruction manual or ask correct service officer when using accessories. The use of improper accessories may cause the risk of injury.
- 21. Do not force machinery.** Work at the speed and capacity at which the machine or accessory was designed.
- 22. Use correct lifting practice.** Always use the correct lifting methods when using machinery. Incorrect lifting methods can cause serious injury.
- 23. Lock mobile bases.** Make sure any mobile bases are locked before using machine.
- 24. Allergic reactions.** Certain metal shavings and cutting fluids may cause an allergic reaction in people and animals, especially when cutting as the fumes can be inhaled. Make sure you know what type of metal and cutting fluid you will be exposed to and how to avoid contamination.
- 25. Call for help.** If at any time you experience difficulties, stop the machine and call you nearest branch service department for help.



# WARNING

## Surface Grinder Safety Instructions

---

Machinery House  
requires you to read this entire Manual before using this machine.

- 1. Maintenance.** Make sure the Surface Grinder is turned off and disconnect from the main power supply and make sure all moving parts have come to a complete stop before any inspection, adjustment or maintenance is carried out.
- 2. Surface Grinder Wheel Condition.** Surface Grinder must be maintained for a proper working condition. Never operate a Surface Grinder with a damaged or badly worn wheels. Replace if required. Scheduled routine maintenance should performed on a scheduled basis.
- 3. Secure your Surface Grinder.** Make sure your Surface Grinder is levelled and fixed to the floor if required.
- 4. Hand Hazard.** Never place your hands or fingers between grinding wheel and the table.
- 5. Leaving a Surface Grinder Unattended.** Always turn the Surface Grinder off and make sure all moving parts have come to a complete stop before leaving the Surface Grinder. Do not leave Surface Grinder running unattended for any reason.
- 6. Avoiding Entanglement.** Surface Grinder guards must be used at all times. Remove loose clothing, belts, or jewelry items. Never wear gloves while machine is in operation. Tie up long hair and use the correct hair nets to avoid any entanglement with the Surface Grinder moving parts.
- 7. Understand the machines controls.** Make sure you understand the use and operation of all controls.
- 8. Power outage.** In the event of a power failure during use of the machine, turn off all switches to avoid possible sudden start up once power is restored.
- 9. Work area hazards.** Keep the area around the Surface Grinder clean from oil, tools, chips. Pay attention to other persons in the area and know what is going on around the area to ensure unintended accidents.
- 10. Starting Surface Grinder.** If a wheel is damaged it may fly apart shortly after start up. To avoid any injury, always stand out or the grinding wheel path when turning it on, allow it to gain full speed and wait for 1 minute before standing in front of Surface Grinder.
- 11. Workpiece Handling.** Always support the workpiece with magnetic vice, or some sort of clamping fixture. Never load or unload the workpiece while grinder is still running.
- 12. Hearing protection and hazards.** Always wear hearing protection as noise generated from Surface Grinder and workpiece vibration can cause permanent hearing loss over time.
- 13. Eye protection.** Always wear safety glasses when using this machine. Small particles become airborne at high speed and can cause serious eye injury. Use Grinding shields on machine at all times.
- 14. Coolants.** Always read and understand the user information listed on the coolant. Some coolants can be hazardous to your health if not store correctly.
- 15. Ensure Grinder is adjusted before operating.** Set the job up correctly and make sure it is adjusted before starting.
- 16. Starting position/speed.** Never turn the Surface Grinder on when the workpiece is resting on the grinding wheel. Allow wheel to reach full speed before grinding.
- 17. Guards.** Do not operate Surface Grinder without the correct guards in place.
- 18. Stopping the grinding wheel.** Do not stop or slow the wheel with your hand or workpiece. Allow the machine to stop on its own.
- 19. Dust hazard.** Grinding causes hazardous dust, which may cause long term respiratory problems if inhaled. Always wear an approved respirator when grinding.
- 20. Call for help.** If at any time you experience difficulties, stop the machine and call you nearest branch service department for help.

## PLANT SAFETY PROGRAM

### **NEW MACHINERY HAZARD IDENTIFICATION, ASSESSMENT & CONTROL**

#### **Surface Grinder**

Developed in Co-operation Between A.W.I.S.A and Australia Chamber of Manufactures  
This program is based upon the Australian Worksafe Standard for Plant(NOHSC.:1010-1994)

Item No.	Hazard Identification	Hazard Assessment	Risk Control Strategies <small>(Recommended for Purchase / Buyer / User)</small>
A	ENTANGLEMENT	HIGH	Eliminate, avoid loose clothing / Long hair etc.
B	CRUSHING	LOW	Secure & support work material when grinding.
C	CUTTING, STABBING, PUNCTURING	MEDIUM	Isolate power to machine prior to any checks or maintenance being carried out. Do not adjust or clean machine until the machine has fully stopped.
D	SHEARING	MEDIUM	Make sure all guards are secured shut when machine is on. Isolate power to machine prior to any checks or maintenance.
E	FRICITION	MEDIUM	Keep hands and body away from grinding wheel.
F	STRIKING	MEDIUM	Ensure grinding wheels are tightly secured on spindle. Wear safety glasses. Stand clear of moving parts on machine. Check grinding wheels for damage before use. Remove all loose objects around moving parts. Ensure jobs are locked tight on table when grinding.
H	ELECTRICAL	MEDIUM	All electrical enclosures should only be opened with a tool that is not to be kept with the machine. Machine should be installed & checked by a Licensed Electrician.
M	HIGH TEMPERATURE	LOW	Wear appropriate protective clothing to prevent hot sparks.
O	OTHER HAZARDS, NOISE.	LOW	Wear hearing protection as required.
Plant Safety Program to be read in conjunction with manufactures instructions			



[www.machineryhouse.com.au](http://www.machineryhouse.com.au)



[www.machineryhouse.co.nz](http://www.machineryhouse.co.nz)

Authorised and signed by:  
Safety officer:



Manager:



Revised Date: Aug-08